

Ⓓ Aufbauanleitung

Ⓕ Notice de montage

Ⓖ Montagehandleiding

Ⓒ Montážní návod

Ⓗ Szerelési útmutató

Ⓓ Montaj talimatları

Ⓖ Assembly instruction

Ⓙ Istruzione di montaggio

Ⓟ Instrukcja montażu

Ⓘ Navod na montaž

Ⓡ Instrucțiuni de montaj

Ⓡ Инструкция по монтажу

37-0008-32-000

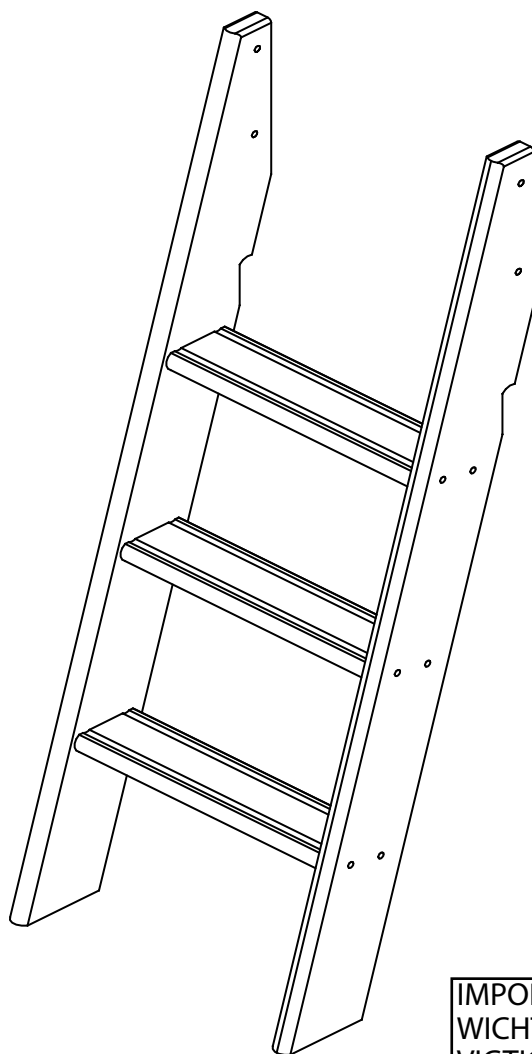

Product fulfill the standard "DIN EN 747-1:2015,DIN EN 747-2:2015"
Produktet opfylder krav til standard "DIN EN 747-1:2015,DIN EN 747-2:2015"
Produkt entspricht der Norm "DIN EN 747-1:2015,DIN EN 747-2:2015"
Produit conforme au standard "DIN EN 747-1:2015,DIN EN 747-2:2015"

IMPORTANT-READ CAREFULLY AND RETAIN
WICHTIG-SORGFÄLTIG LESEN UND AUFBEWAHREN
VIGTIGT-LÆS grundigt igennem og opbevar
IMPORTANT-LIRE ATTENTIVEMENT ET A CONSERVER

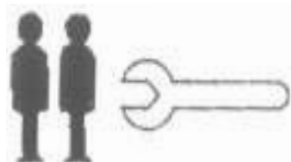
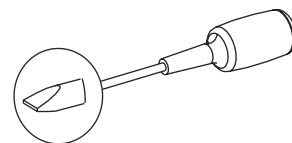
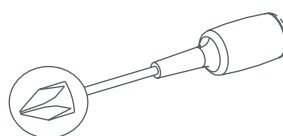
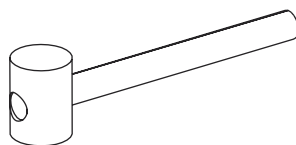
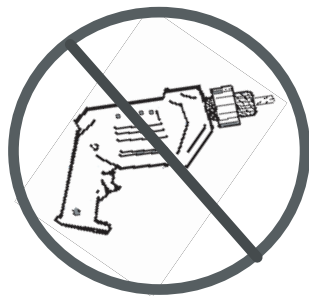

DIN EN 747-1+A1:2015
DIN EN 747-2+A1:2015



Service • Assistenza • Dienstverlening • Serwis Servis • Szerviz • Сервисная служба

Name • Nom • Nome • Naam • Nazwa • Иméно • Názov
Név • Denumire • Isim • Название

Nr. • No. • N° • Č • Sz • Номер

Typ • Type • Tip • Tipus • Druh • Тiро • Тип

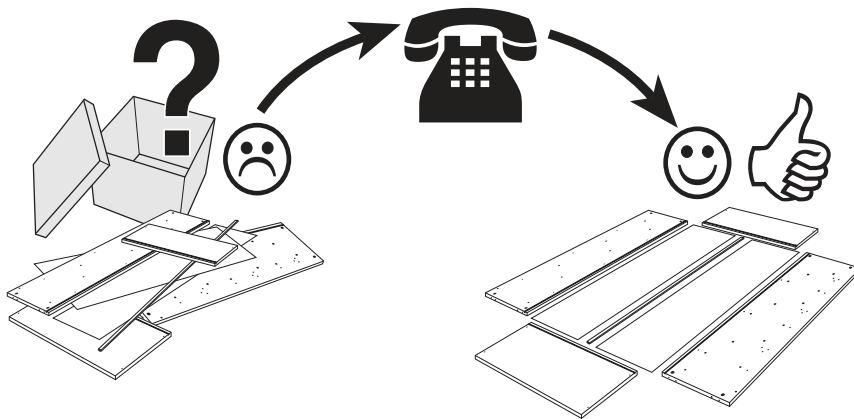
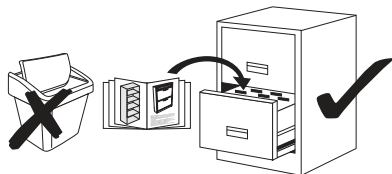

Detail specification

A.i. Nr.	Article Nr.	pcs
19	013018-32	x3
20	013019-32	x2

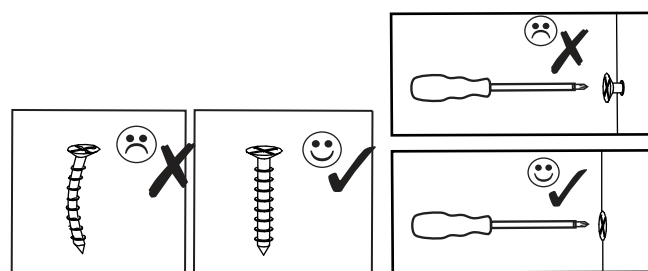
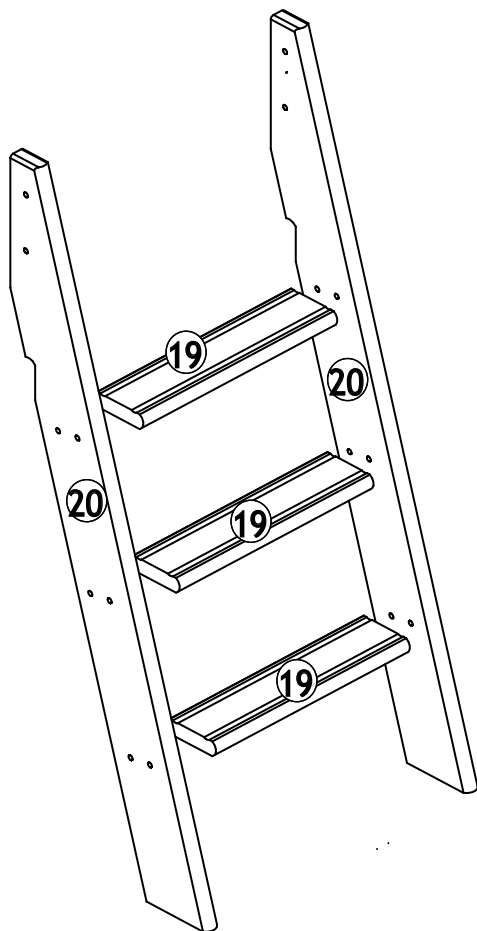

Fitting specification

A.i. Nr.	Article Nr.	Dimentions	pcs
o	1-000025-07	M6x85	x2
p	1-000026-07	M6x120	x2
t	1-000027-07	8x15	x2
e	1-000014-57	8x13	x4
r	1-000028-07	7x60	x12
s	1-000029-07	4x50	x2

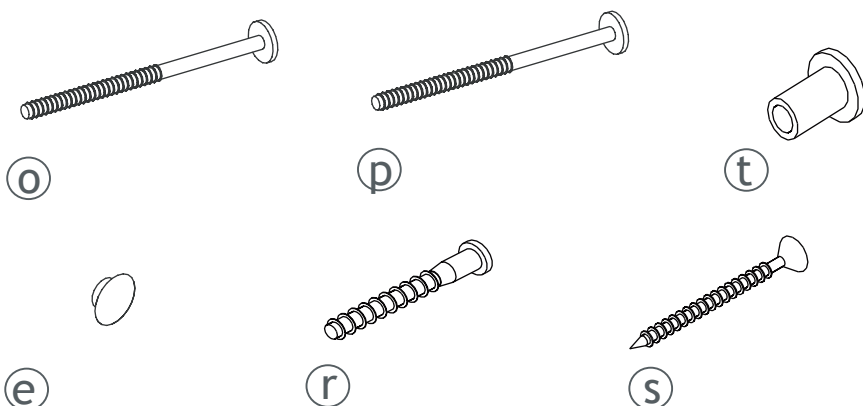

1-000001=

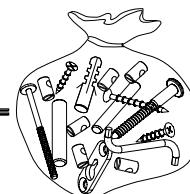

1.

Mark of maximal mattress height level
 Mærke for: Madras max. højde
 Markierung für die maximale Matratzenhöhe
 Marquage de l'hauteur maximale du matelas

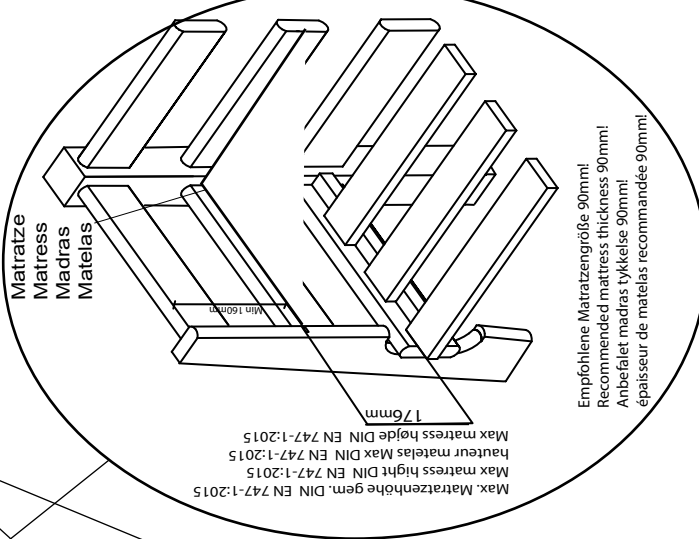
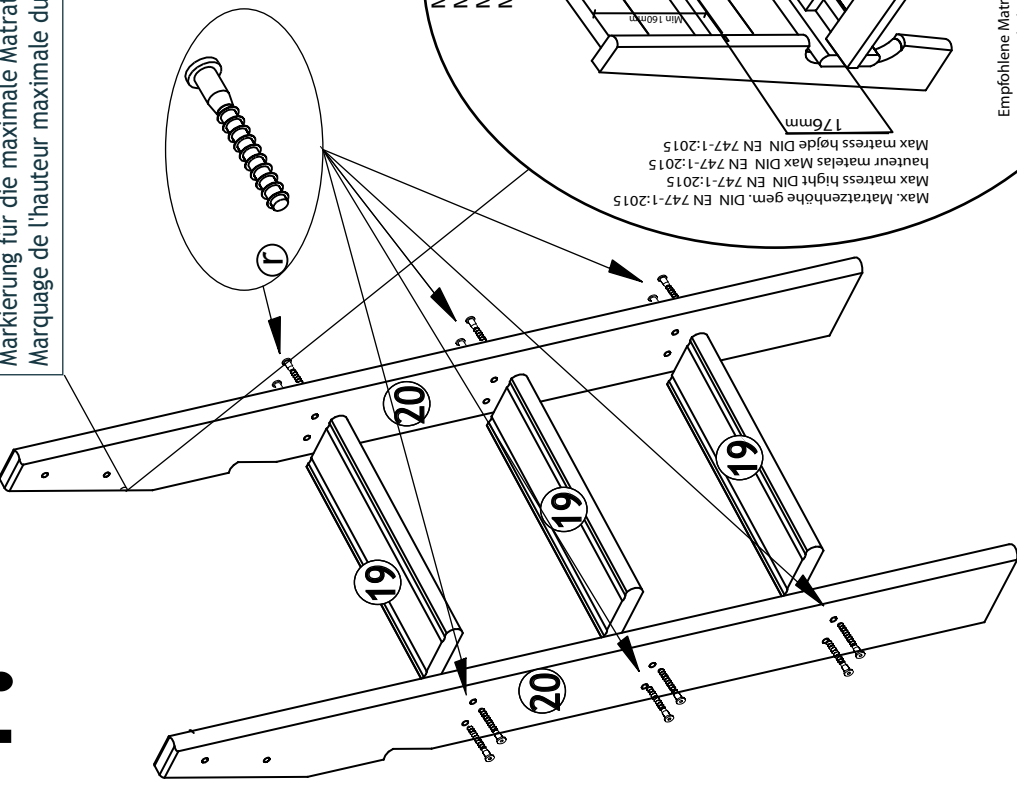

VORSICHT-dass sich Kinder mit Gegenständen, z. B. Stricken, Schnüren, Kordeln, Gurten, Bändern, die an einem Etagenbett/Hochbett befestigt oder abhängig sind, strangulieren können
Important - that children with objects such as ropes, cords, cords, straps, bands, beginning at bed / loft mounted or are dependent, strangulation

DE Halten Sie das Bett stets in Kontakt mit der Wand. Falls das nicht möglich ist, darf der Abstand zwischen der oberen Absturzicherung und der Wand nicht mehr als 75 mm betragen oder der Abstand muß größer als 230 mm sein. Alle Schrauben und Befestigungen müssen immer fest sein. Stellen Sie sicher, dass es keine lose Schrauben gibt. DIN EN 747-1:2015
UK Please hold the bed straight in contact with the wall. If that is not possible, the distance between the upper safety rail and the wall may not be larger than 75 mm or it must be more than 230 mm. All screws and fittings must always be tight. Ensure that there are not loose screws. DIN EN 747-1:2015

2.

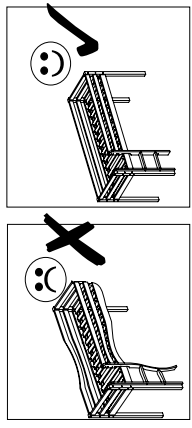
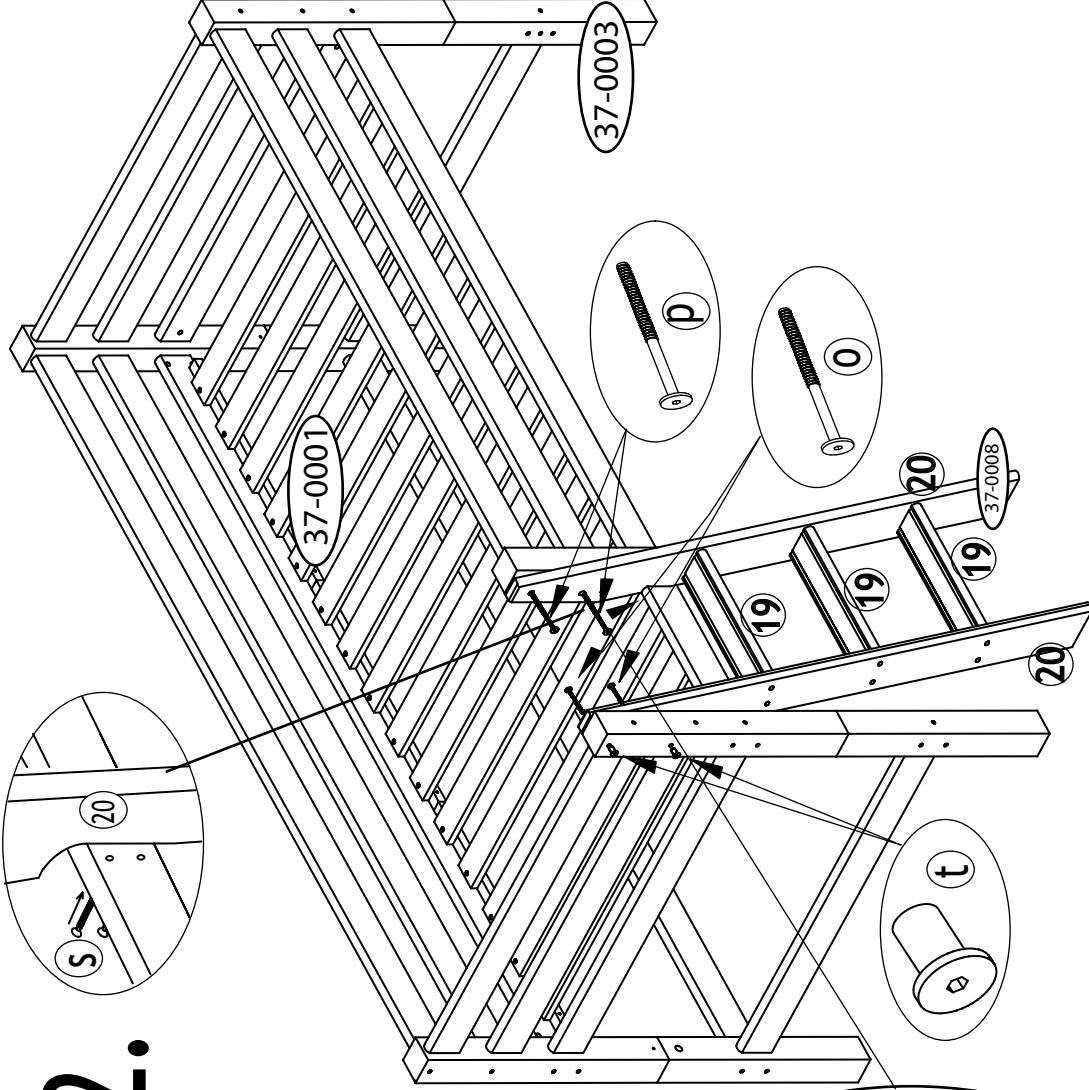

Close free holes with caps
 Luk alle huller med propper
 Schliessen Sie die offenen Löcher mit den Deckkappen
 Fermez les trous découverts avec les chapes



FR Tenez le lit droit contact avec le mur. Si ce n'est pas possible, la distance entre le rail supérieur de sûreté et le mur peut ne pas être plus grande que 75 millimètres ou elle doit être plus de 230 millimètres. Vérifier que la quincaillerie est bien vissée en permanence, faire attention à des vis qui peuvent se dévisser. DIN EN 747-1:2015
DK Hold venligt sengen i lige kontakt med væggen. Er dette ikke muligt må afstanden mellem øverste sengehest og væg ikke være mere end 75mm eller skal den være mere end 230mm. Alle skrue og beslag skal altid være stramt til. Vær opmærksom på, at der ikke er løse skrue. DIN EN 747-1:2015