

- Ⓓ Aufbauanleitung
- Ⓕ Notice de montage
- Ⓔ Handleiding voor de montage
- Ⓒ Montážní návod
- Ⓗ Szerelési útmutató
- Ⓓ Montaj talimatları
- Ⓖ Assembly instruction
- Ⓘ Istruzione di montaggio
- ⒲ Instrukcja montażu
- Ⓔ Návod na montáž
- Ⓓ Instrucțiuni de montaj
- Ⓓ Инструкция по монтажу

# 36-1002-32-09A

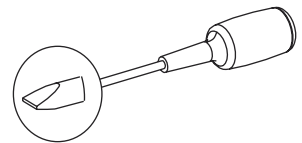

**DIN EN 747-1+A1:2015**  
**DIN EN 747-2+A1:2015**

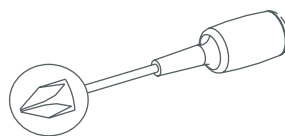
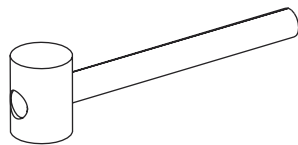
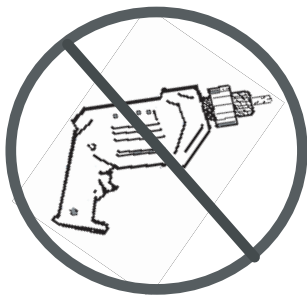
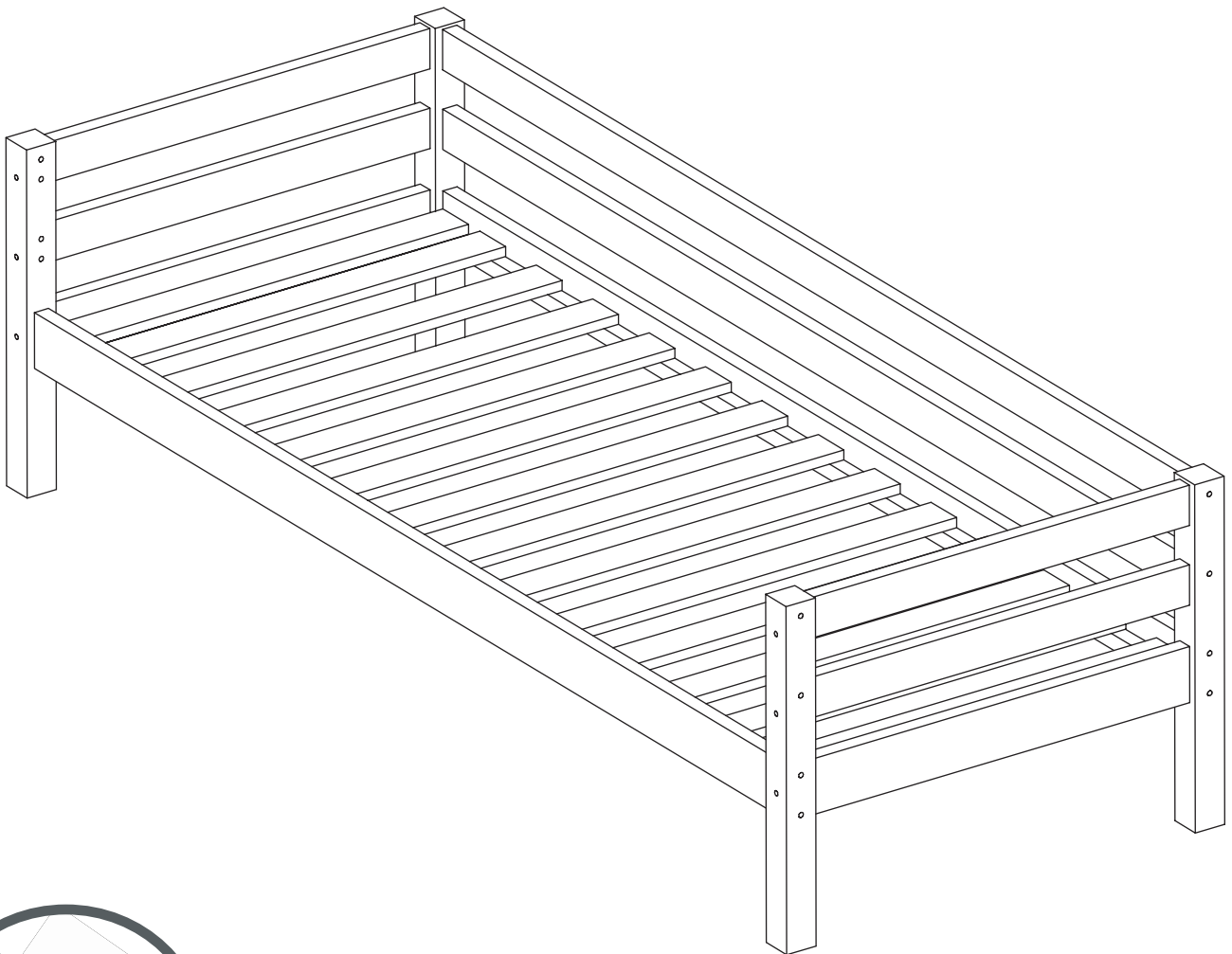

# Service • Assistenza • Dienstverlening • Serwis Servis • Szerviz • Сервисная служба

Name • Nom • Nome • Naam • Nazwa • Jméno • Názov  
Név • Denumire • Isim • Название

Nr. • No. • N° • Č • Sz • Номер

Typ • Type • Tip • Tipus • Druh • Тип • Тип

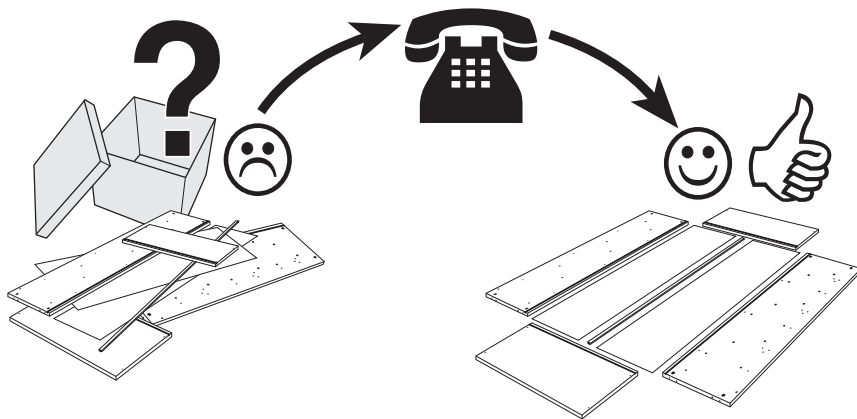
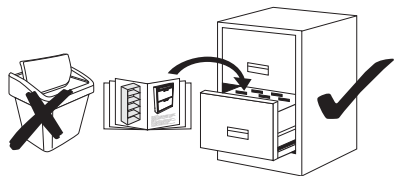

0  
10  
20  
30  
40  
50  
60  
70  
80  
90  
100  
110  
120  
130  
140  
150  
160  
170  
180

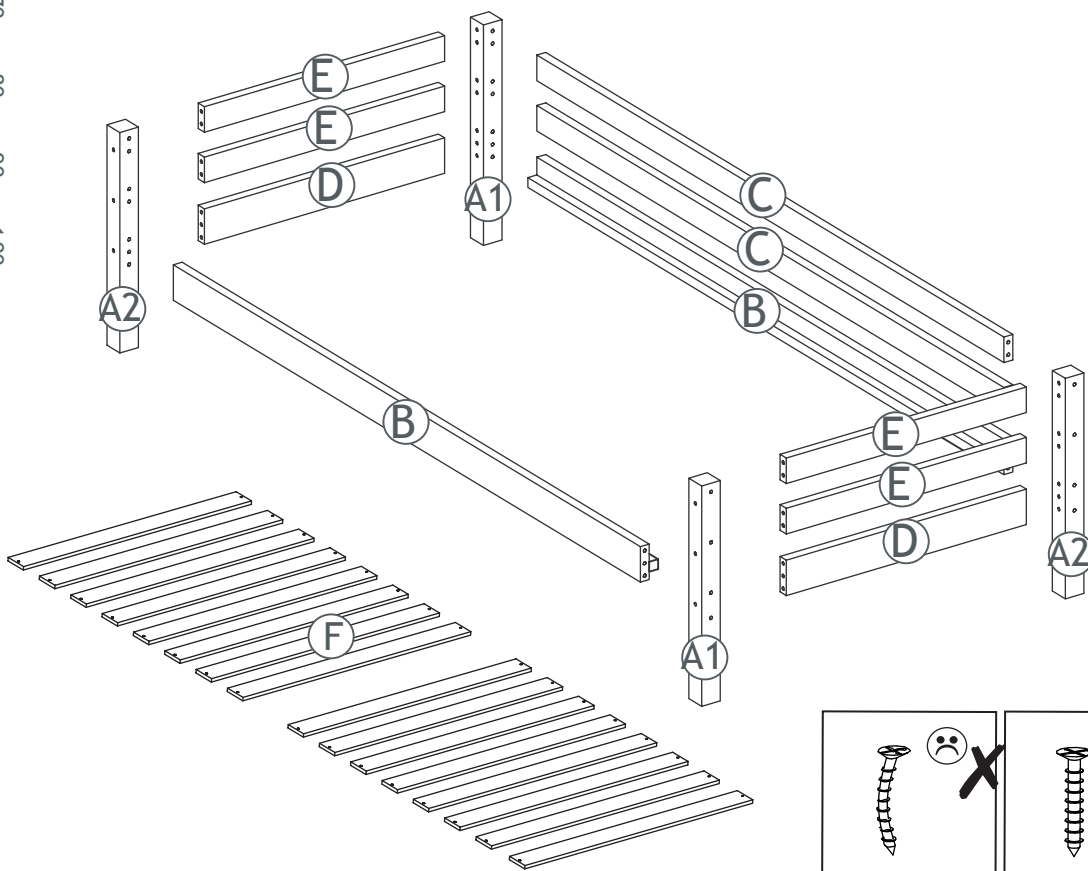

A.i. Nr.	Article Nr.	pcs
A1	111110-32	x2
A2	111111-32	x2
B	008213-32	x2
C	008210-32	x2
D	008410-32	x2
E	008421-32	x4
F	108820-00	x16

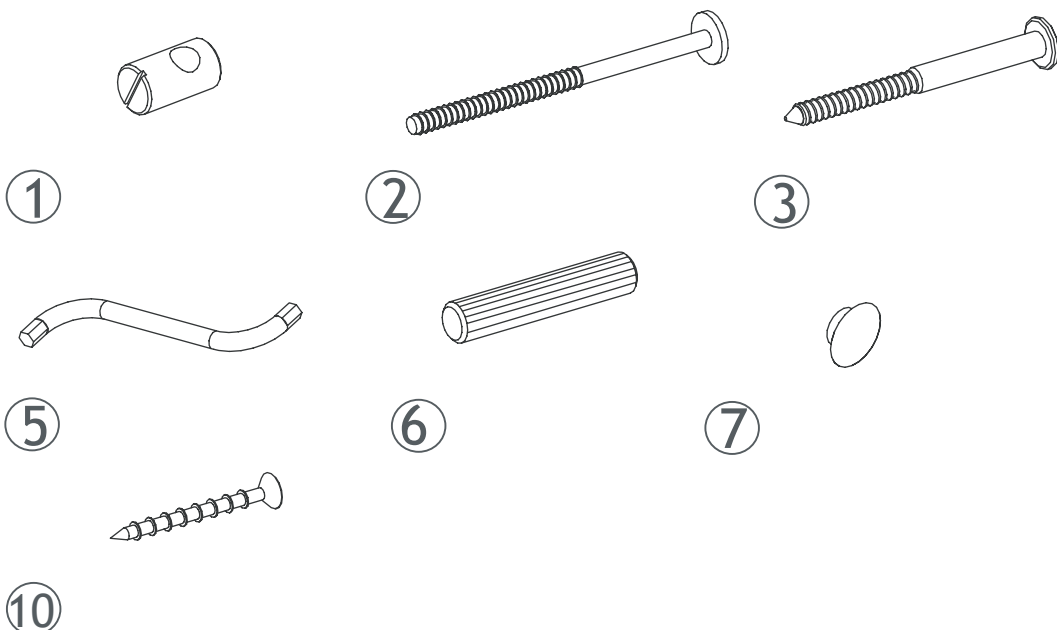
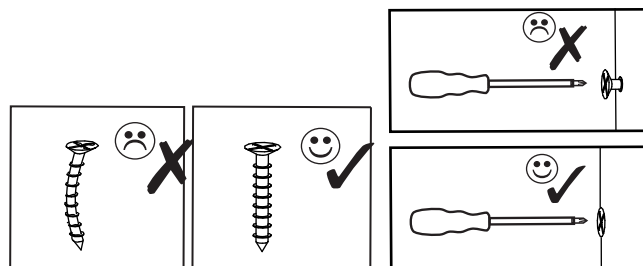

		mm	
1	1-000095-07	M6x10/6	x12
2	1-000096-07	M6x80	x12
3	1-000097-07	6,3x80	x12
5	1-000015-07	Z4	x1
6	1-000013-00	8x40	x24
7	1-000014-57	6x8	x12
10	1-000012-07	3x30	x32

1-000001=

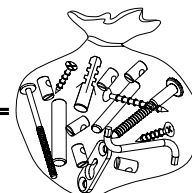

1.

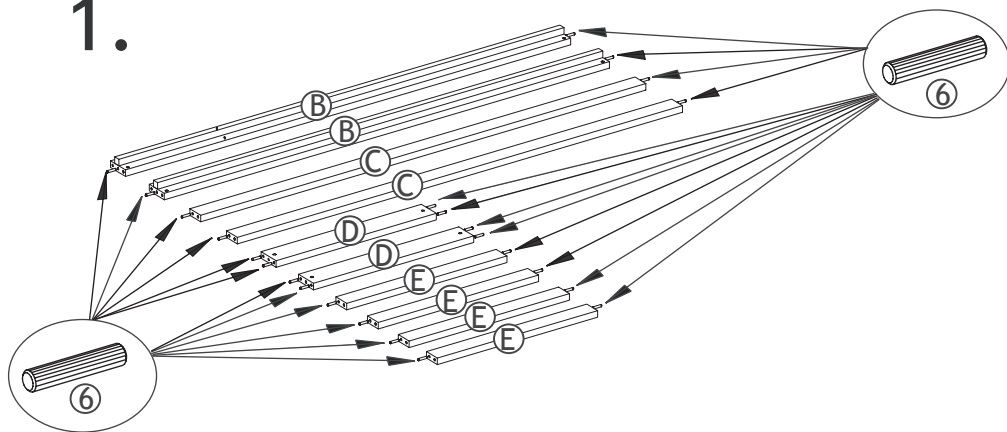

2.x2

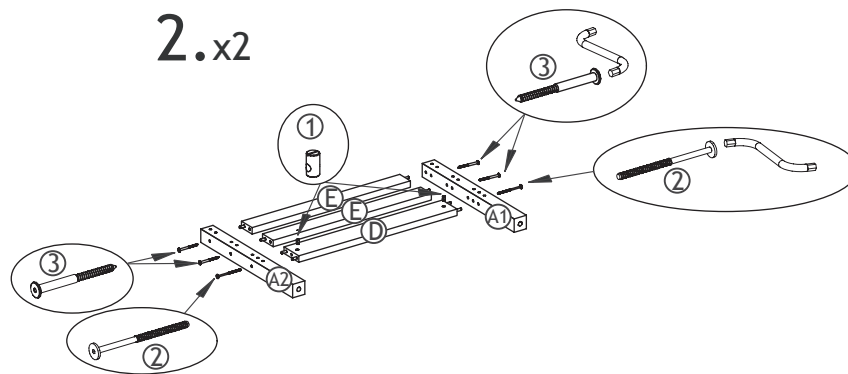

3.

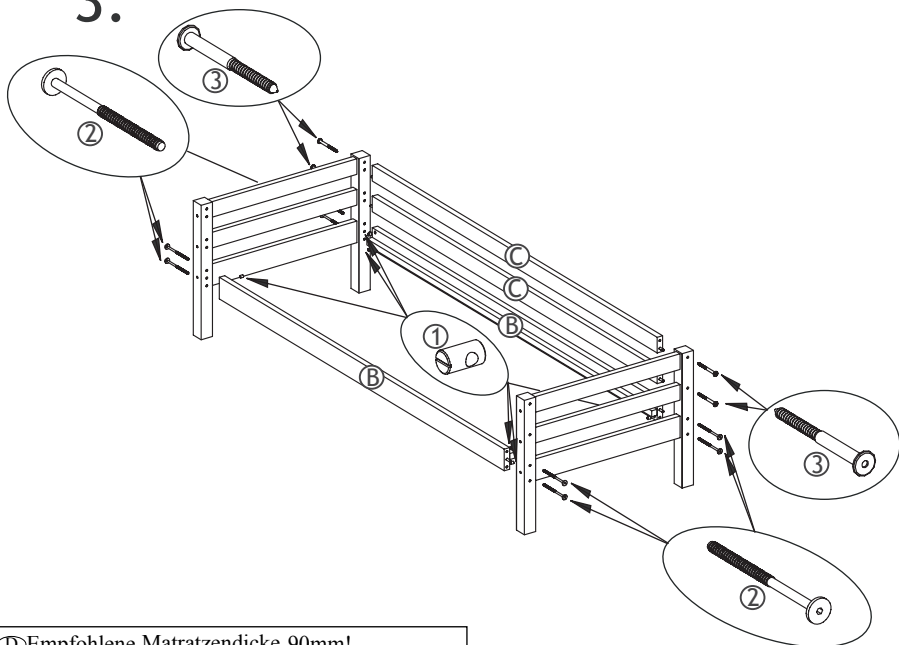

4.

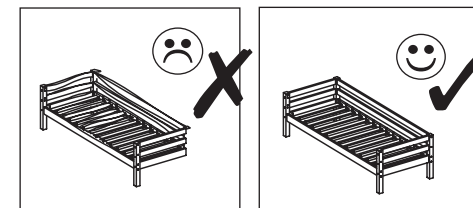
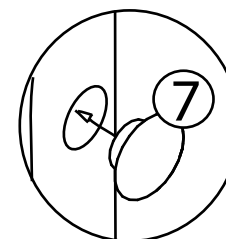
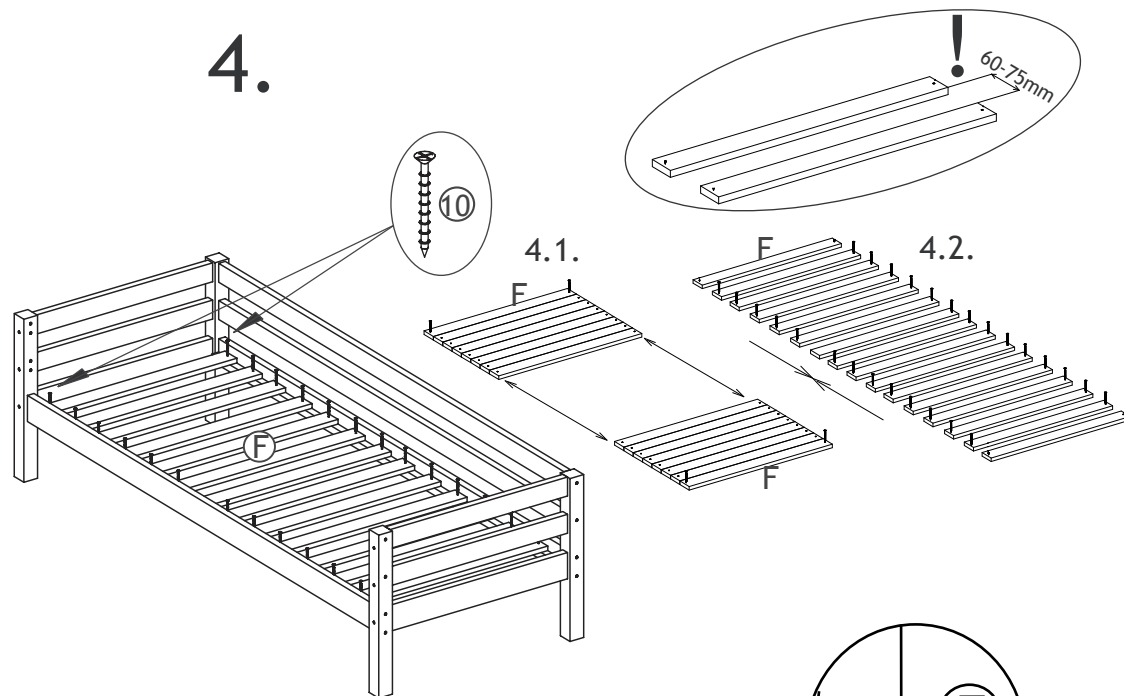

Ⓛ Empfohlene Matratzendicke 90mm!  
 Ⓜ Epaisseur de matelas recommandée : 90mm!  
 Ⓝ Aanbevolen matras dikte is 90 mm  
 Ⓢ Doporučená tloušťka matrace je 90 mm!  
 Ⓣ Az ajánlott matracméret 90 mm!  
 Ⓟ Önerilen yatak şilte kalınlığı 90 mm'dir!  
 Ⓠ Recommended mattress thickness 90mm!  
 Ⓡ Spessore consigliato del materasso 90mm!  
 Ⓟ Zalecana grubość materacu 90 mm!  
 Ⓡ Odporučaná hrúbka matraca 90 mm!  
 Ⓡ Grosimea recomandată a saltelei este de 90mm!  
 Ⓡ Рекомендуемая высота матраса- 90мм

Ⓛ Hergestellt von: Hoppekids SIA / Novadnieki / LV-3801 / Saldus / www.hoppekids.com DIN EN 747-1+A1:2015  
 Ⓜ Fabriqué par: Hoppekids SIA / Novadnieki / LV-3801 / Saldus / www.hoppekids.com DIN EN 747-1+A1:2015  
 Ⓝ Vervaardigd door: Hoppekids SIA / Novadnieki / LV-3801 / Saldus / www.hoppekids.com DIN EN 747-1+A1:2015  
 Ⓢ Výrobce: Hoppekids SIA / Novadnieki / LV-3801 / Saldus / www.hoppekids.com DIN EN 747-1+A1:2015  
 Ⓣ Framleitt af: Hoppekids SIA / Novadnieki / LV-3801 / Saldus / www.hoppekids.com DIN EN 747-1+A1:2015  
 Ⓟ Tarafından üretilmiştir: Hoppekids SIA / Novadnieki / LV-3801 / Saldus / www.hoppekids.com DIN EN 747-1+A1:2015  
 Ⓠ Made by: Hoppekids SIA / Novadnieki / LV-3801 / Saldus / www.hoppekids.com DIN EN 747-1+A1:2015  
 Ⓡ Prodotto da: Hoppekids SIA / Novadnieki / LV-3801 / Saldus / www.hoppekids.com DIN EN 747-1+A1:2015  
 Ⓡ Wyprodukowane przez: Hoppekids SIA / Novadnieki / LV-3801 / Saldus / www.hoppekids.com DIN EN 747-1+A1:2015  
 Ⓡ Výrobca: Hoppekids SIA / Novadnieki / LV-3801 / Saldus / www.hoppekids.com DIN EN 747-1+A1:2015  
 Ⓡ Produs de: Hoppekids SIA / Novadnieki / LV-3801 / Saldus / www.hoppekids.com DIN EN 747-1+A1:2015  
 Ⓡ Изготовитель: Hoppekids SIA / Novadnieki / LV-3801 / Saldus / www.hoppekids.com DIN EN 747-1+A1:2015

Ⓓ Aufbauanleitung

Ⓕ Notice de montage

Ⓖ Handleiding voor de montage

Ⓒ Montážní návod

Ⓗ Szerelési útmutató

Ⓓ Montaj talimatları

Ⓖ Assembly instruction

Ⓙ Istruzione di montaggio

Ⓟ Instrukcja montażu

Ⓙ Navod na montaž

Ⓡ Instrucțiuni de montaj

Ⓡ Инструкция по монтажу

# 36-1034-32-09A

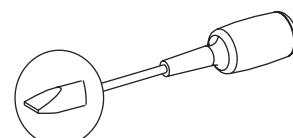
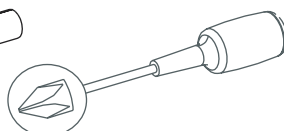
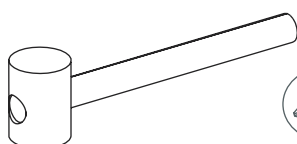
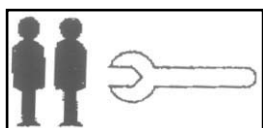
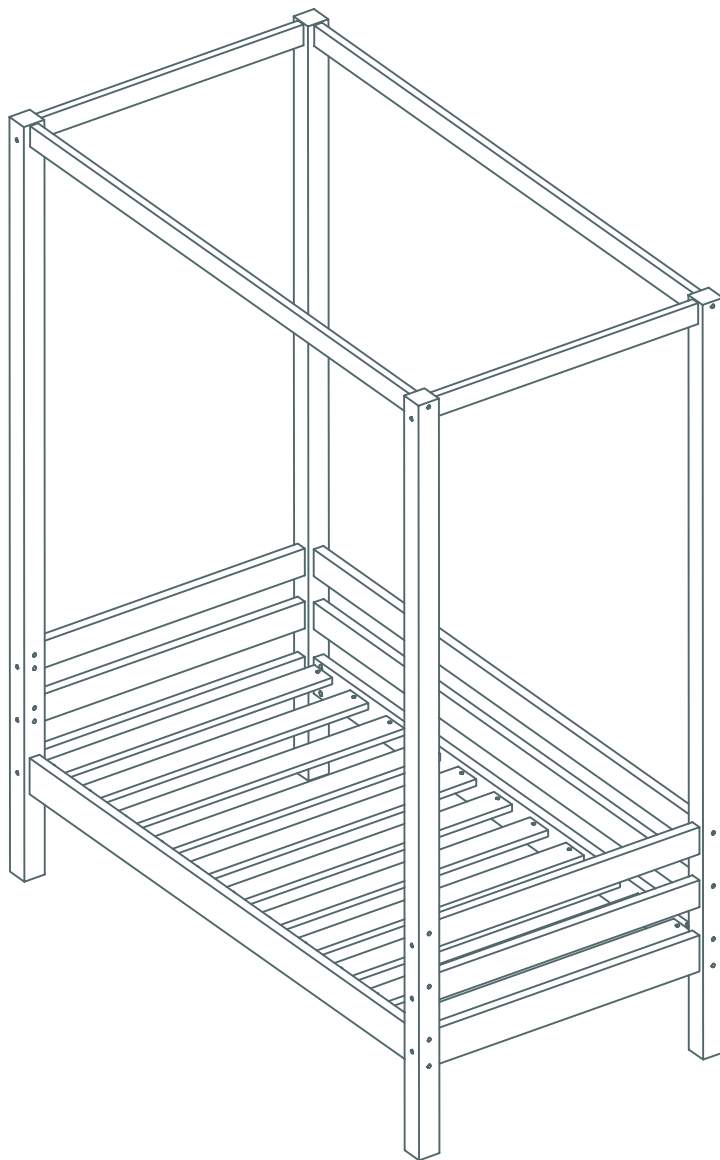

# Service • Assistenza • Dienstverlening • Serwis Servis • Szerviz • Сервисная служба

Name • Nom • Nome • Naam • Nazwa • Jméno • Názov  
Név • Denumire • Isim • Название

Nr. • No. • N° • Č • Sz • Номер

Typ • Type • Tip • Tipus • Druh • Тіро • Тип

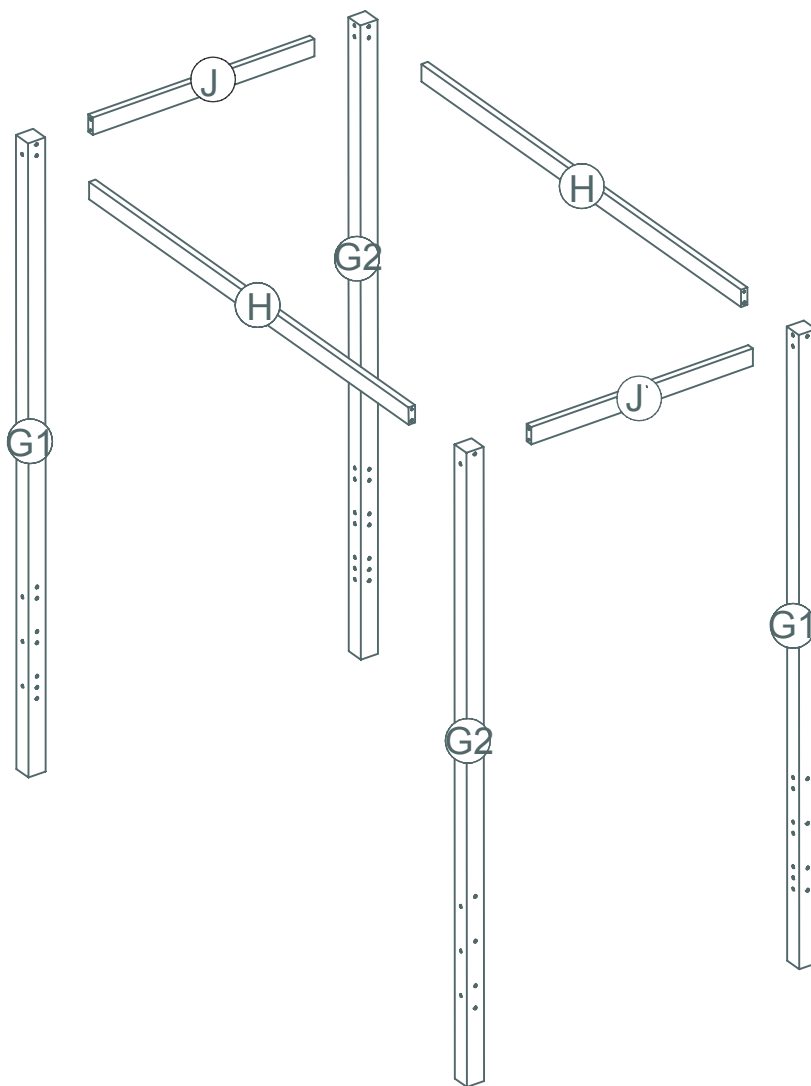
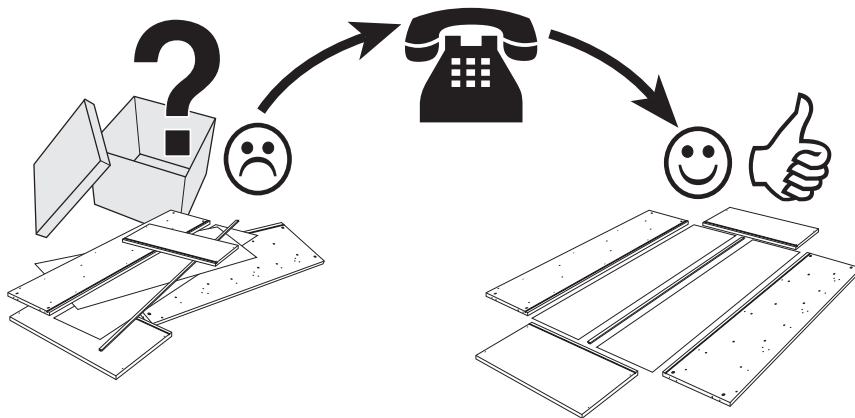
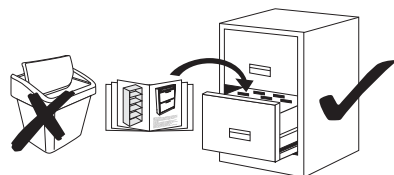

G1	147111-32	x2
G2	147110-32	x2
H	147213-32	x2
J	147311-32	x2

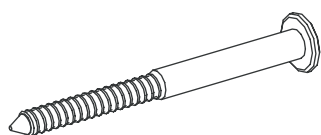
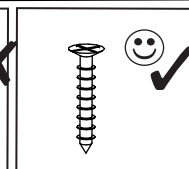
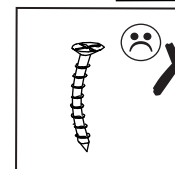
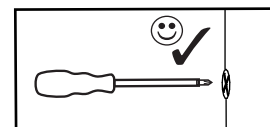
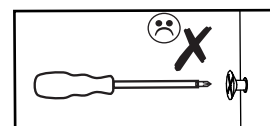

8

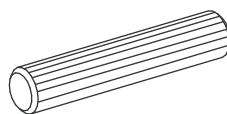

9



10

1-000001=

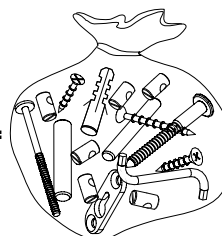

		mm	
8	1-000097-07	6,3x80	x8
9	1-000013-00	8x40	x8
10	1-000015-07	Z4	x1

# 1.

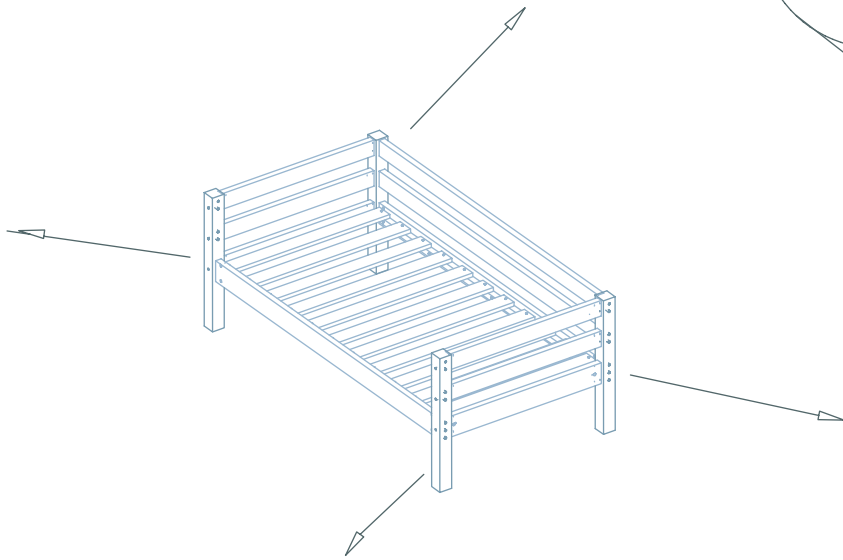
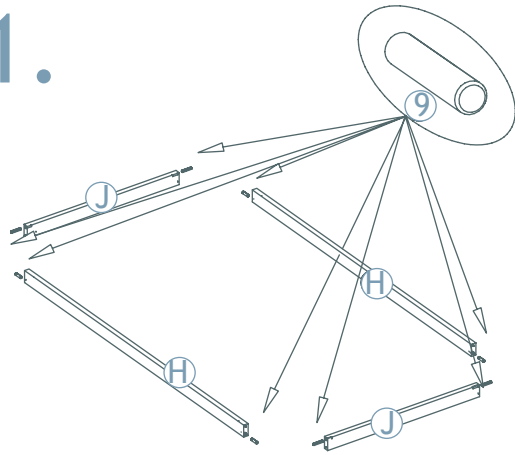

# 2.

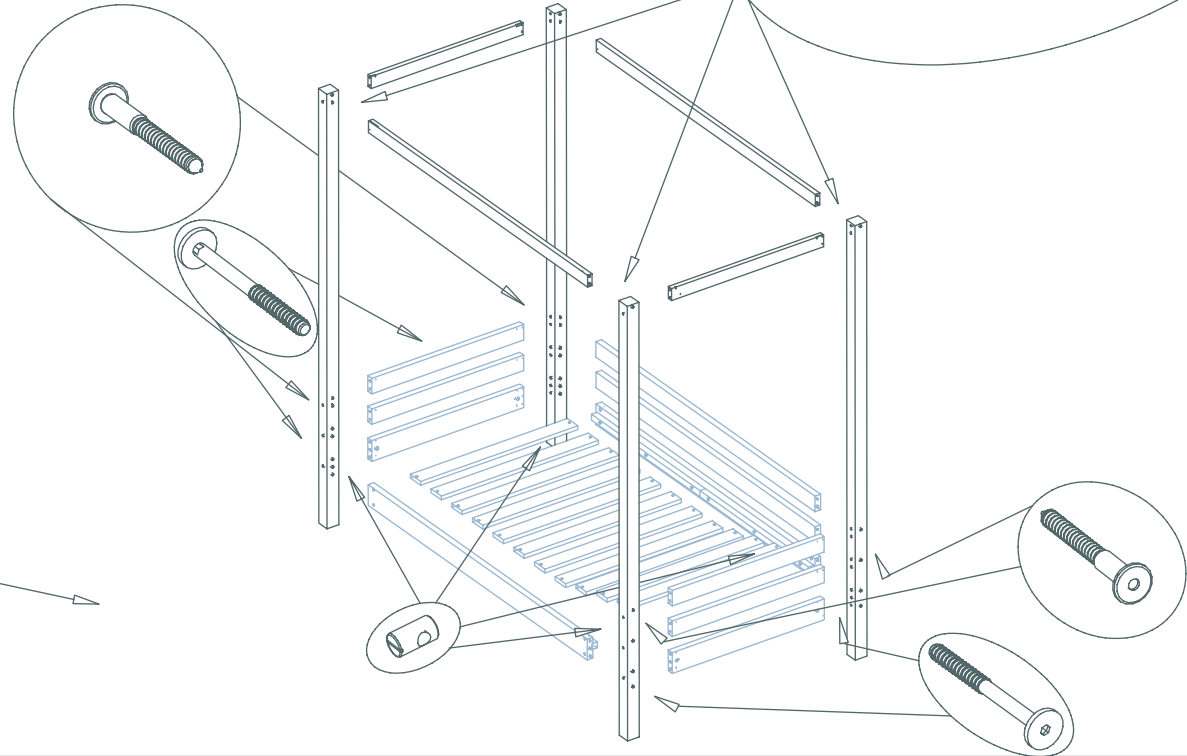

- Ⓛ Achtung! Wenn das Bett und 4-Poster-Modul auf gleicher Zeit gekauft sind, bitte die kurzen Beine des Bettes nicht montieren, sondern verwenden Sie die Beine des 4-Poster-Modul mit der Schraube aus dem Bett
- Ⓛ Attention! Si l'achat du lit et du module à quatre colonnes a été effectué en même temps, veuillez ne pas monter les pieds de lit de petites dimensions, mais servez-vous des pieds du module à quatre colonnes avec la vis du lit.
- Ⓛ Attention! Bij gelijktijdige aankoop van bed en 4-poster module, monteer dan niet de korte benen van het bed, maar gebruik de poten van de 4-poster module met de schroef van het bed.
- Ⓛ Pozor! Pokud kupujete postel společně s modelem 4 sloupků, při montáži použijte krátké nohy s modelu 4 sloupků a šrouby s postele.
- Ⓛ Figyelem! Ha egyszerre egy ágyat és 4 poszteres modult vásárol, akkor kérem, ne szerelje össze az ágy rövid lábait, hanem a 4 poszteres modul lábait használja az ágy csavarjaival.
- Ⓛ Dikkat! Karyola ve 4-poster modulünün aynı zamanda alınması durumunda, karyolanın 4 kısa ayağını takmayın. Karyola için verilen vidaları kullanarak 4-poster modulünün ayaklarını kullanın.
- Ⓛ Attention! If purchase of bed and 4-poster module at the same time, please do not assemble the short legs of the bed, but use the legs of the 4-poster module with the screw from the bed.
- Ⓛ Attenzione! Se acquistate il letto e il baldacchino allo stesso tempo, si prega di non montare le gambe corte del letto ma usare le gambe del baldacchino con le viti del letto.
- Ⓛ Uwaga! W przypadku zakupu łóżka wraz z modulem z czterema stojakami nie trzeba montować do łóżka krótkie nóżki; zamiast nich zamontuj nóżki modułu z 4 stojakami i użyj śrub z kompletu łóżka.
- Ⓛ Pozor! V prípade, že kupujete posteľ a model so 4 stĺpkami zároveň, pri montáži použijte krátke nohy z modelu 4 stĺpkov a šrouby z postele.
- Ⓛ Atentie! In cazul in care ati cumparat un pat impreuna cu un modul cu baldachin, va rugam sa nu montati picioarele scurte ale patului ci cele ale modulului, folosind suruburile de la pat.
- Ⓛ Внимание! При покупке кровати вместе с модульной системой, при сборке не используйте короткие детали ног от кровати, надо использовать длинные детали от модульной системы и винты от кровати.

Ⓛ Aufbauanleitung

Ⓒ Assembly instruction

Ⓓ Brugsanvisning

# 36-1048-32-00A

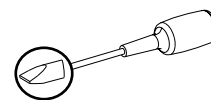
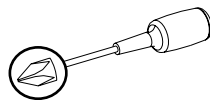
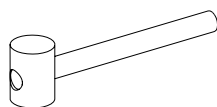
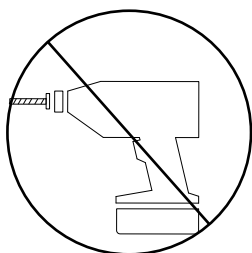
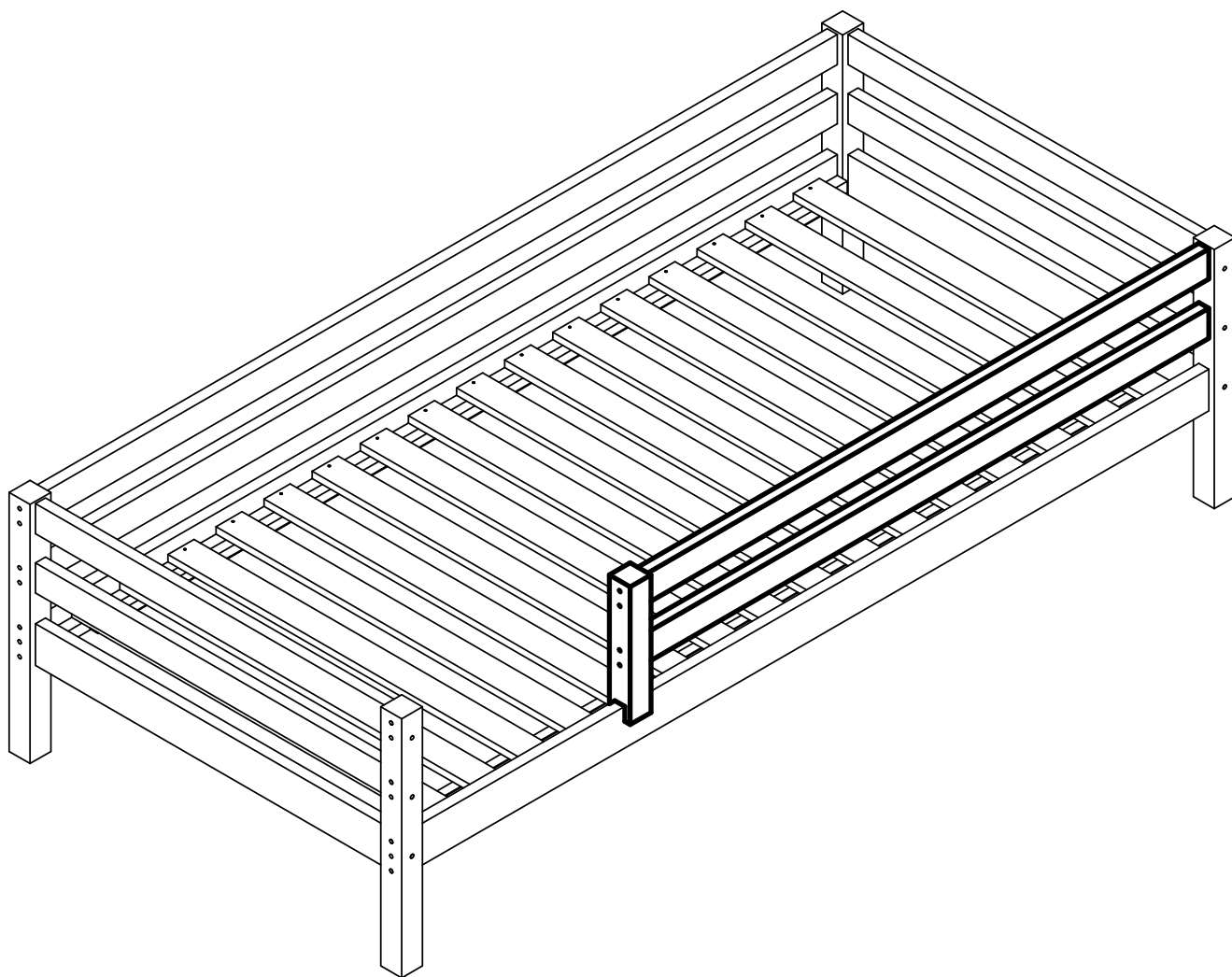

♥ [www.hoppekids.com](http://www.hoppekids.com)

Ⓛ [facebook.com/hoppekids](https://facebook.com/hoppekids)

Ⓢ [@hoppekids\\_official](https://instagram.com/hoppekids_official)

Hoppekids SIA, Novadnieki, LV-3801, Saldus

(D) WICHTIG, FÜR SPÄTERE FRAGEN AUFBEWAHRES: SORGFÄLTIG LESEN  
 (GB) IMPORTANT, RETAIN FOR FUTURE REFERENCE: READ CAREFULLY  
 (DK) VIGTIGT, GEM TIL FREMTIDIG BRUG: LÆS GRUNDIGT

(D) Service	(GB) Service	(DK) Service
(D) Name	(GB) Name	(DK) Navn
(D) Nr.	(GB) Nr.	(DK) Nr.
(D) Typ	(GB) Type	(DK) Type

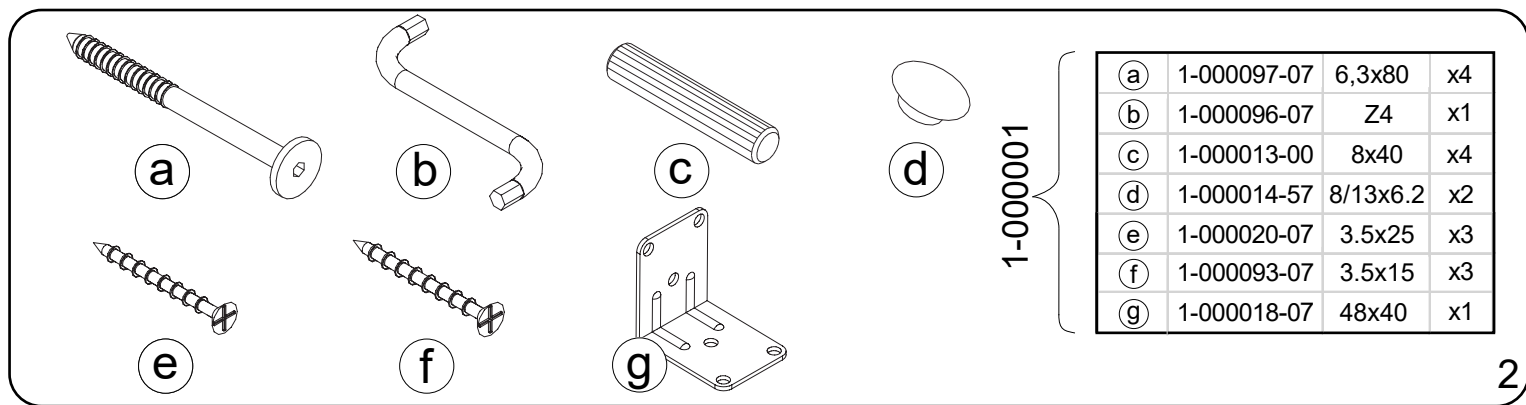
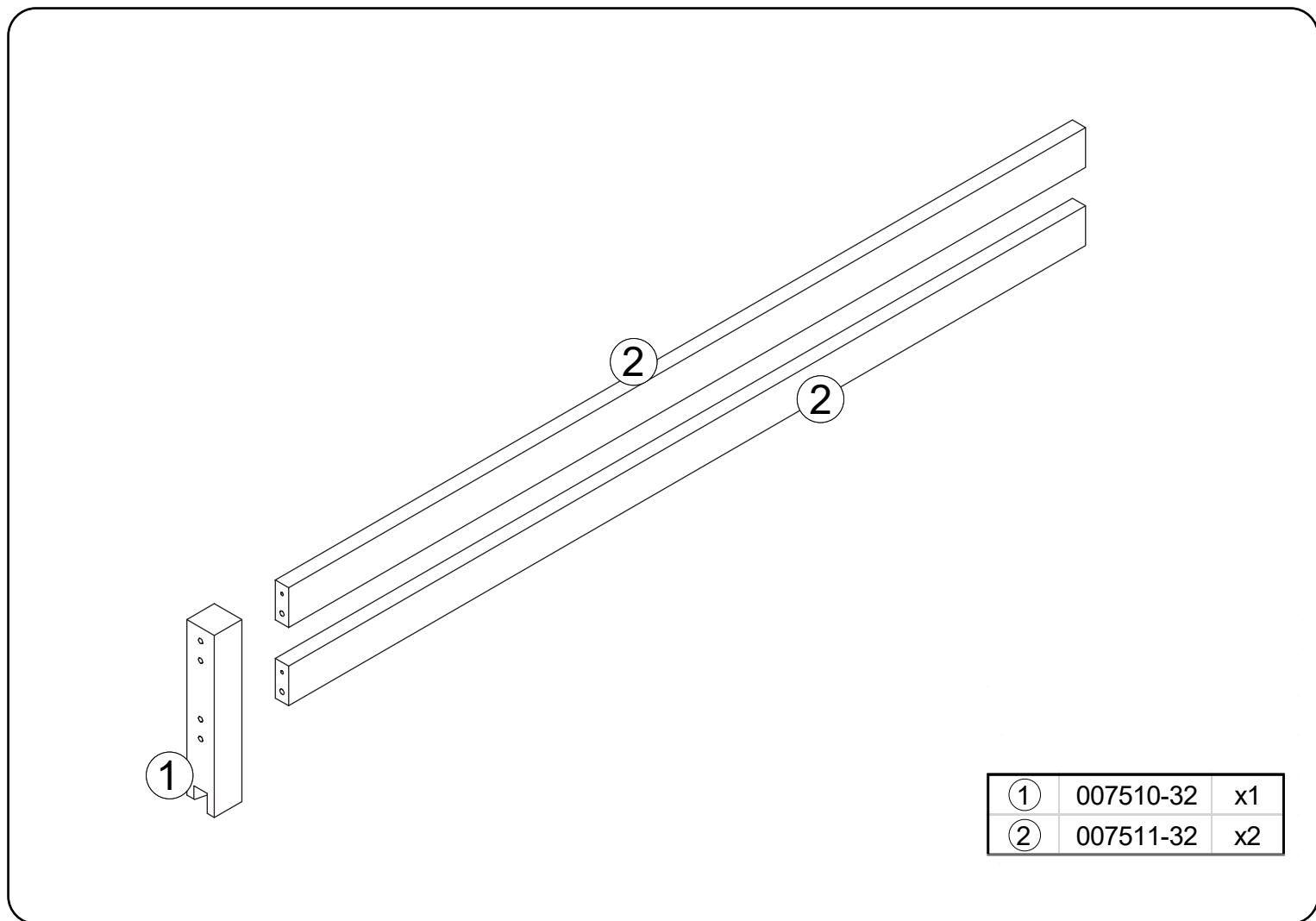



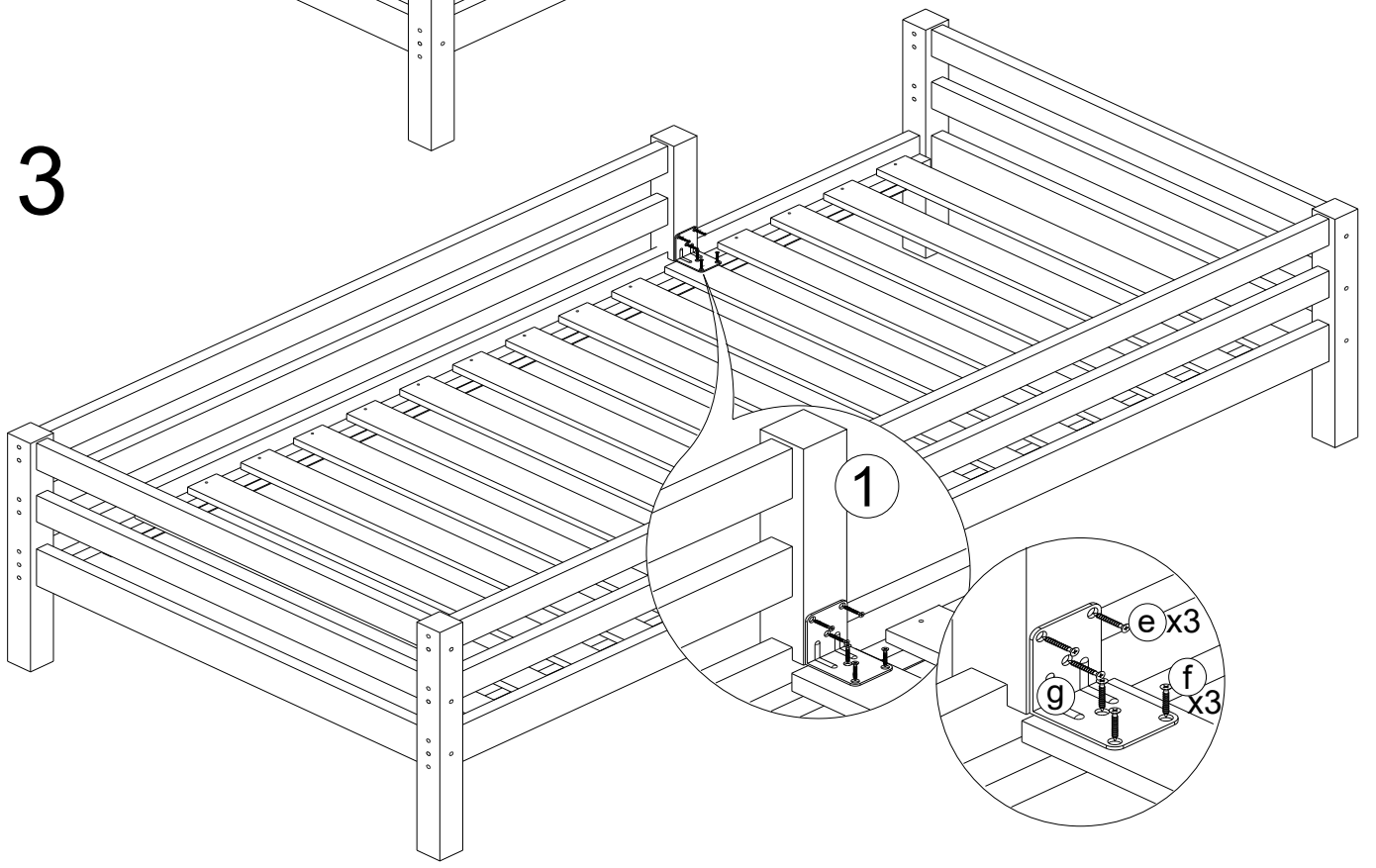
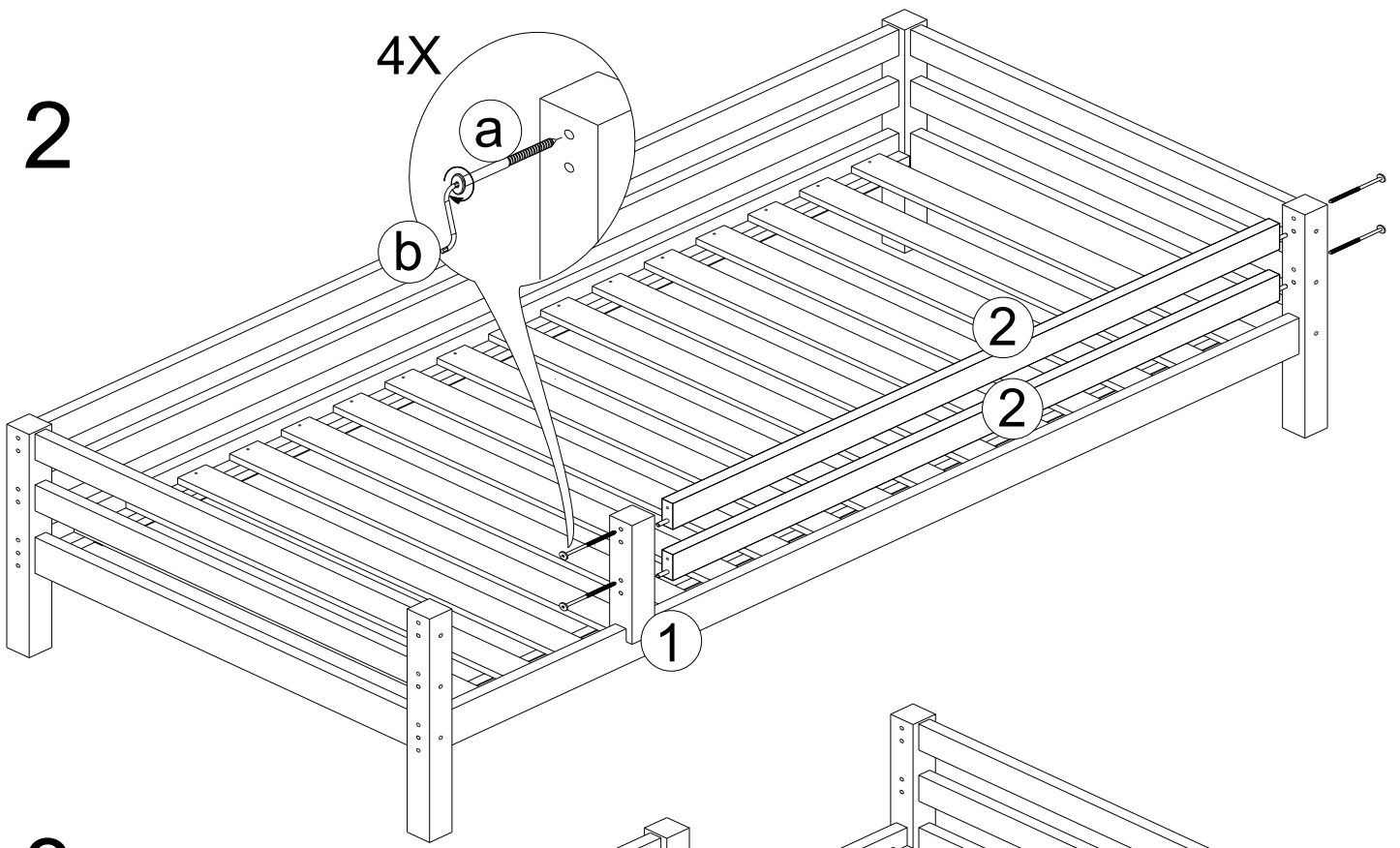
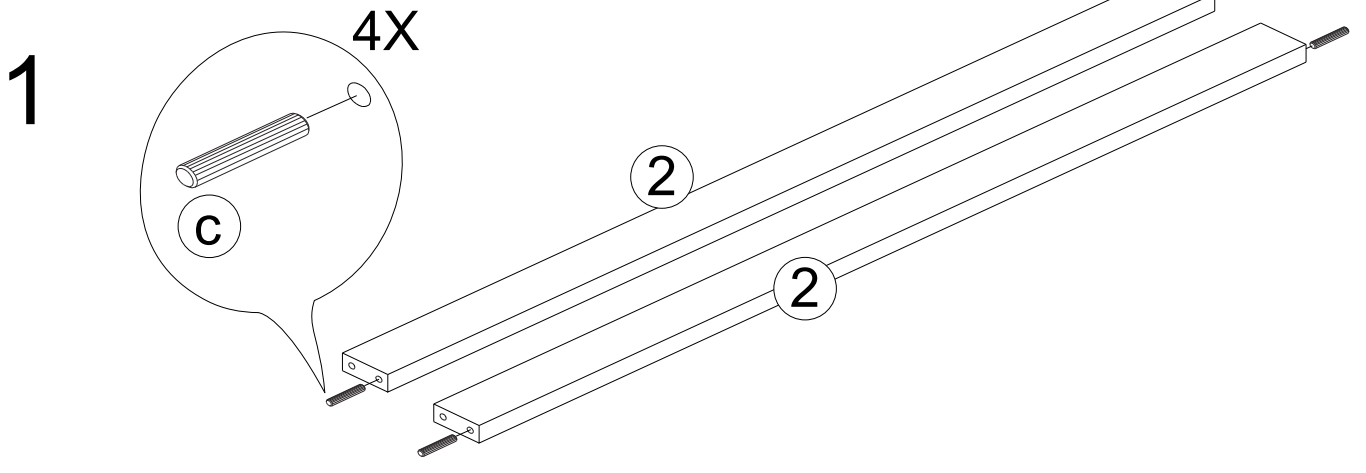

Ⓓ Aufbauanleitung

Ⓕ Notice de montage

Ⓖ Handleiding voor de montage

Ⓒ Montážní návod

Ⓗ Szerelési útmutató

Ⓓ Montaj talimatları

Ⓖ Assembly instruction

Ⓘ Istruzioni di montaggio

Ⓗ Instrukcja montażu

Ⓐ Navod na montaž

Ⓘ Instrucțiuni de montaj

Ⓔ Инструкция по монтажу

# 36-1010-32-000

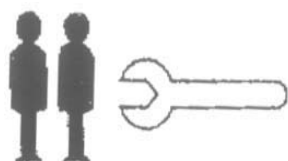
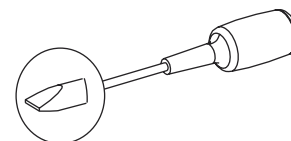
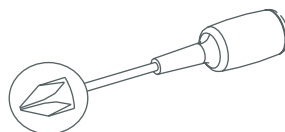
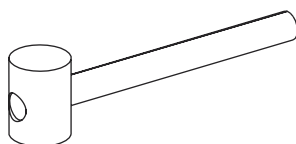
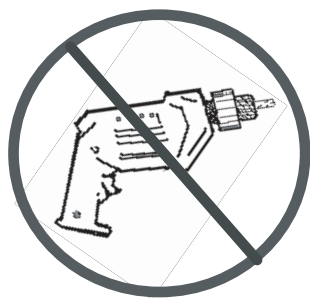
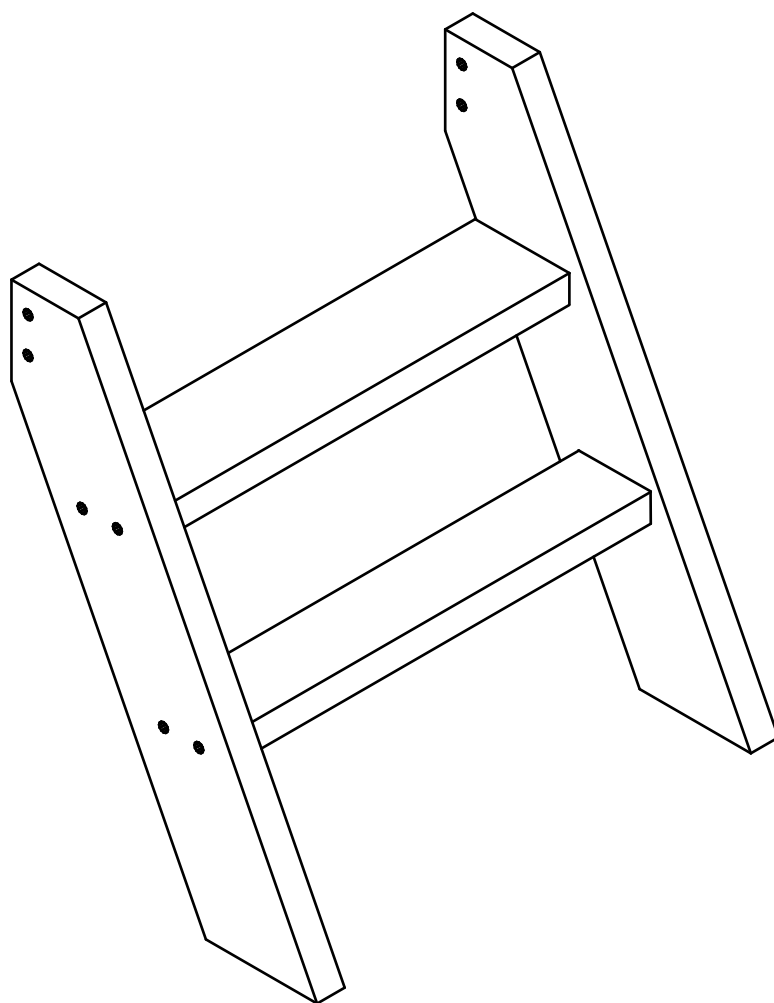

DIN EN 747-1:2015  
DIN EN 747-2:2015



0  
10  
20  
30  
40  
50  
60  
70  
80  
90  
100  
110  
120  
130  
140  
150  
160  
170  
180

Service  
Serwis

Dienstverlening  
Servis

Dienst kaart  
Сервисная служба

Name • Naam • Naam • Isim • Название

Nr. • No. • Номер

Typ • Type • Тип • Тип

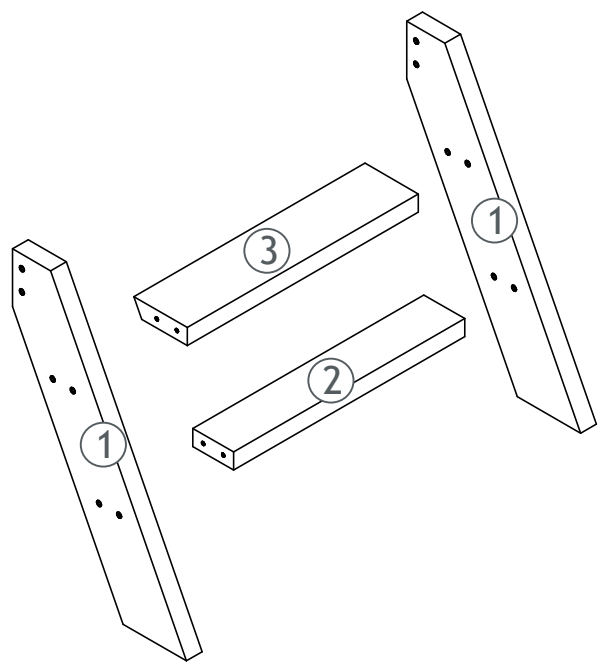
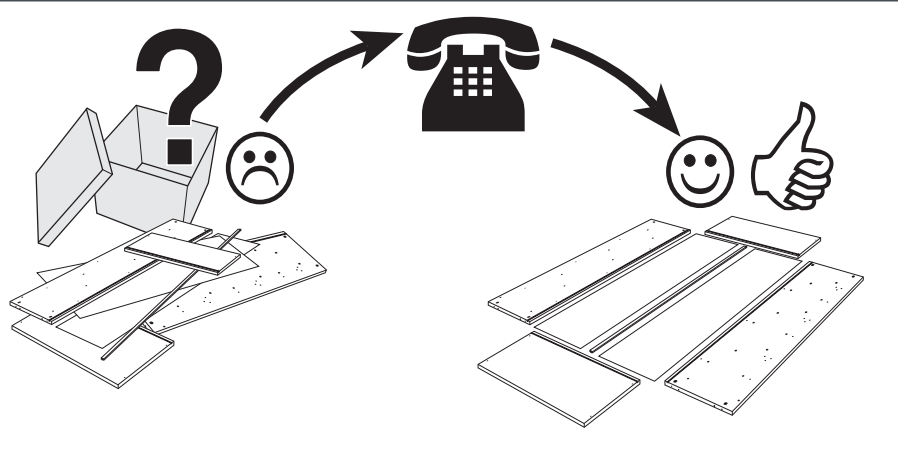
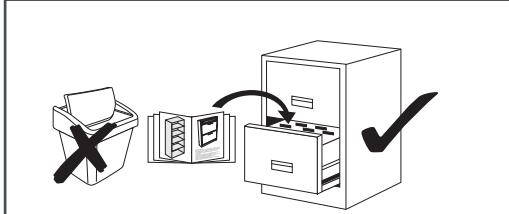

①	198100-32	x2
②	198101-32	x1
③	198102-32	x1

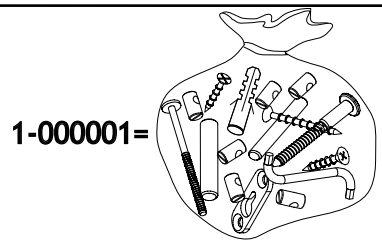
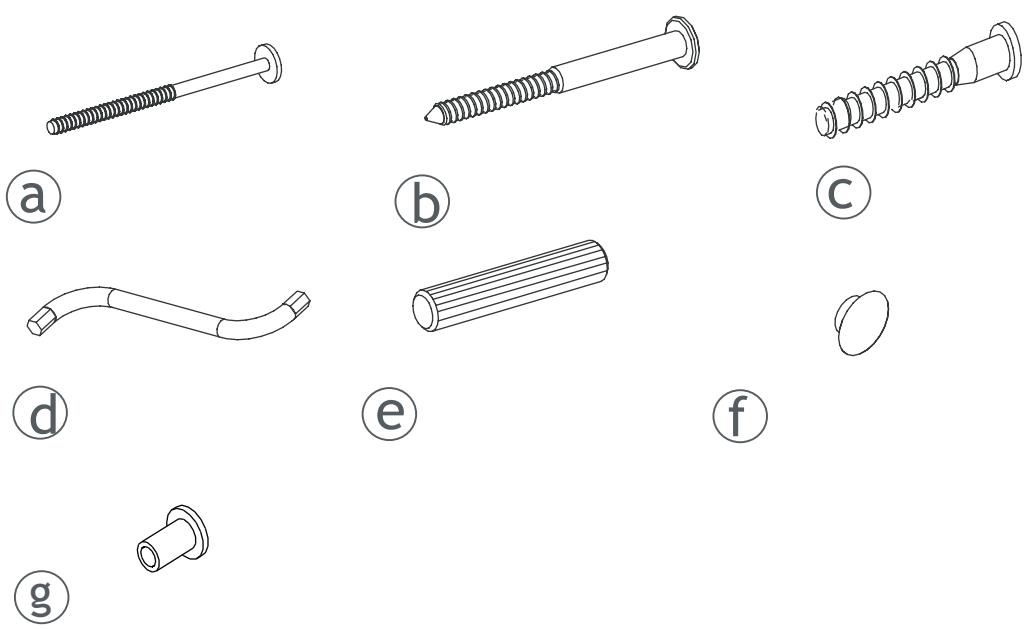
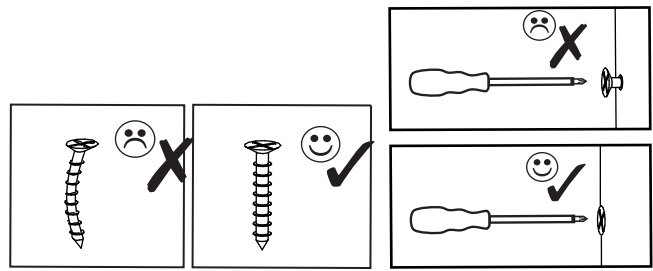

		mm	
a	1-000200-07	M6x70	x1
b	1-000098-07	6,3x90	x1
c	1-000099-07	7x50	x8
d	1-000015-07	Z4	x1
e	1-000109-00	8x30	x2
f	1-000014-57	6x8	x2
g	1-000012-07	8x15	x1

# 1.

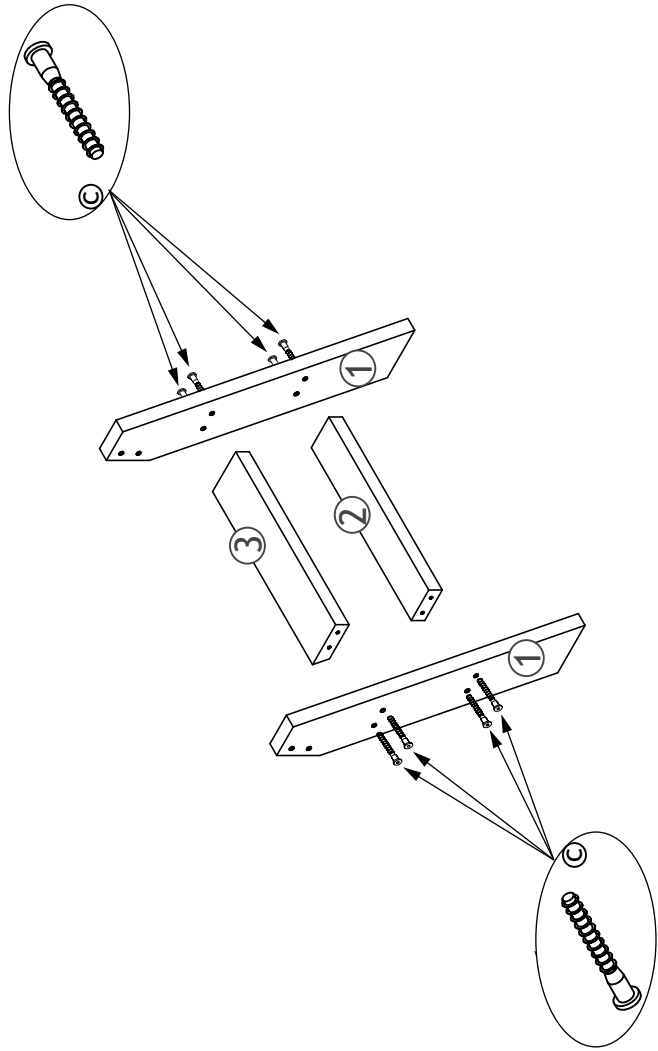

- Ⓓ Empfohlene Matratzengröße 90mm!
- Ⓔ Espaisseur de matelas recommandée : 90mm!
- Ⓕ Aanbevolen matras dikte is 90 mm
- Ⓖ Doporučená tloušťka matrace je 90 mm!
- Ⓗ Az ajánlott matracméret 90 mm!
- Ⓚ Önerilen yatak şilte kalınlığı 90 mm'dir!
- Ⓒ Recommended mattress thickness 90mm!
- Ⓛ Spessore consigliato del materasso 90mm!
- Ⓜ Zalecana grubość materacu 90 mm!
- Ⓢ Odporúčaná hrúbka matrace 90 mm!
- Ⓔ Grosimea recomandată a saltelei este de 90mm!
- Ⓔ Рекомендуемая высота матраса - 90мм

# 2.

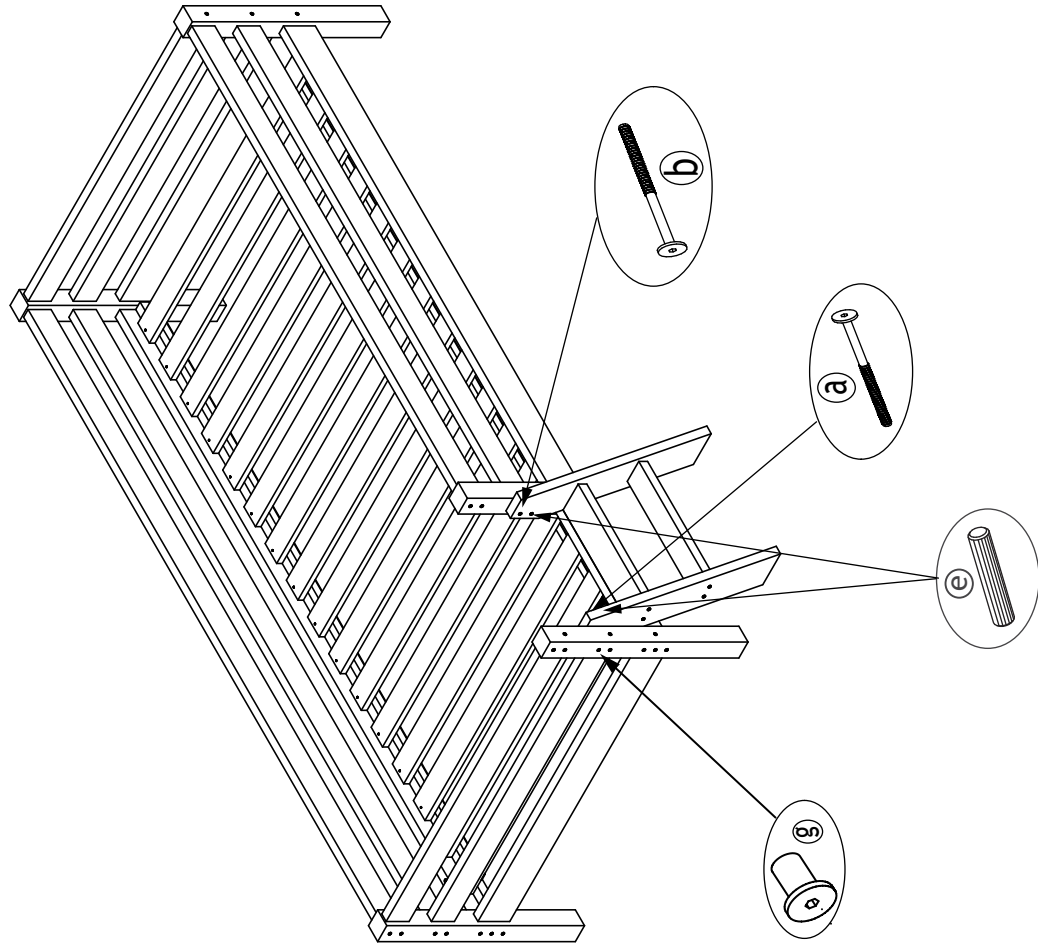

Close free holes with caps  
 Luk alle huller med propper  
 Schliessen Sie die offenen Löcher mit den Deckkappen  
 Fermez les trous découverts avec les chapes

