

Ⓛ Aufbauanleitung

Ⓛ Notice de montage

Ⓛ Montagehandleiding

Ⓛ Montážní návod

Ⓛ Szerelési útmutató

Ⓛ Montaj talimatları

Ⓛ Assembly instruction

Ⓛ Istruzione di montaggio

Ⓛ Instrukcja montażu

Ⓛ Navod na montaž

Ⓛ Instrucțiuni de montaj

Ⓛ Инструкция по монтажу

37-0001-32-12A

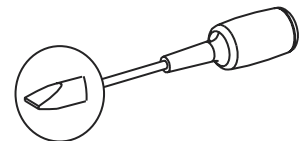
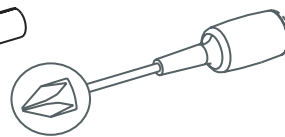
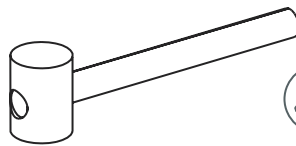
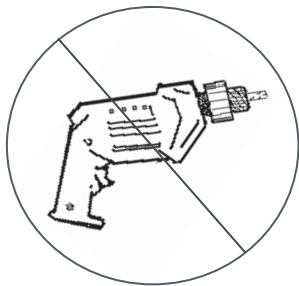
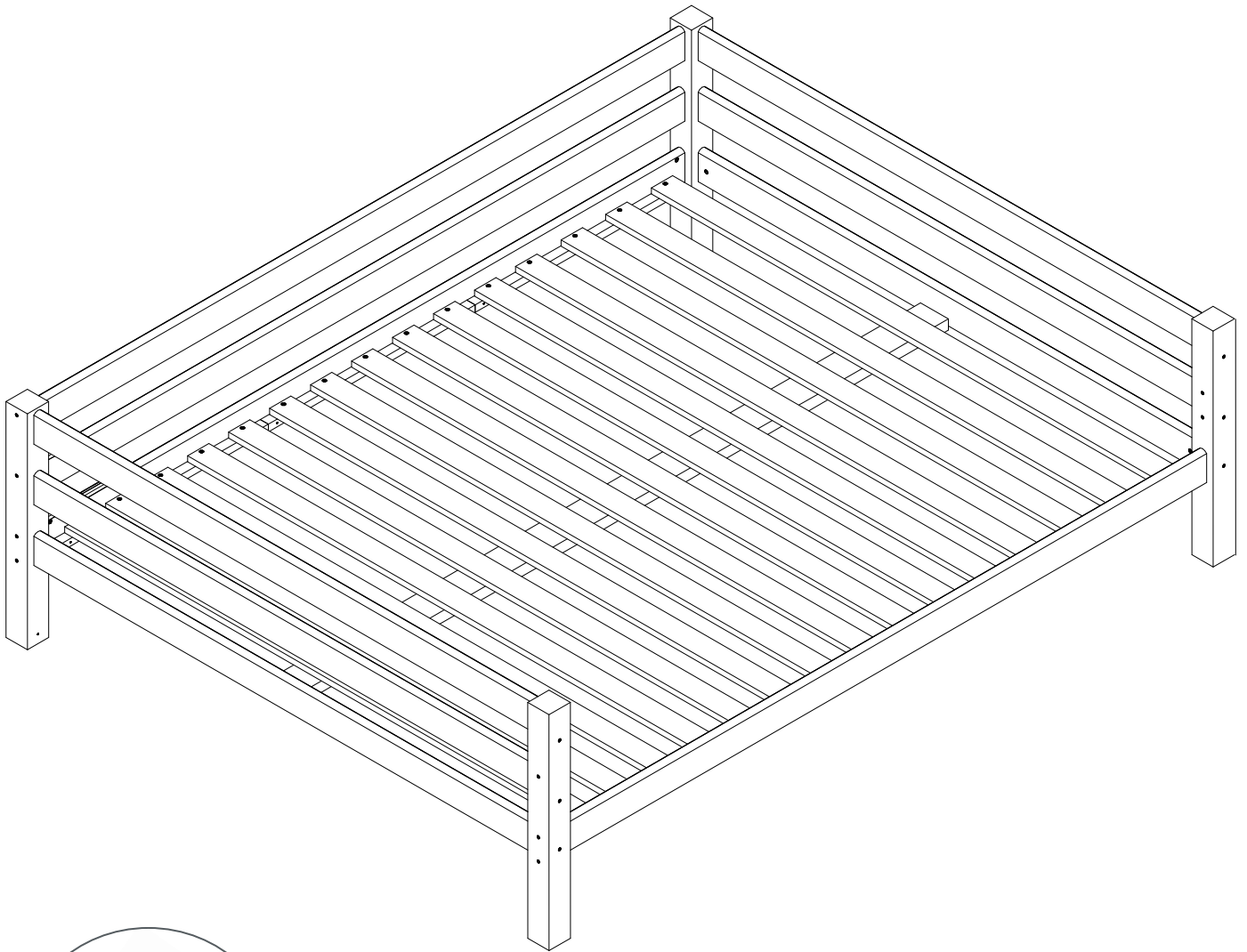

DIN EN 747-1:2015
DIN EN 747-2:2015

Service • Assistenza • Dienstverlening • Serwis Servis • Szerviz • Сервисная служба

Name • Nom • Nome • Naam • Nazwa • Jméno • Názov
Név • Denumire • Isim • Название

Nr. Nr. • No. • N° • Č • Sz • Номер

Typ • Тип • Type • Tip • Tipus • Druh • Тіро • Тип

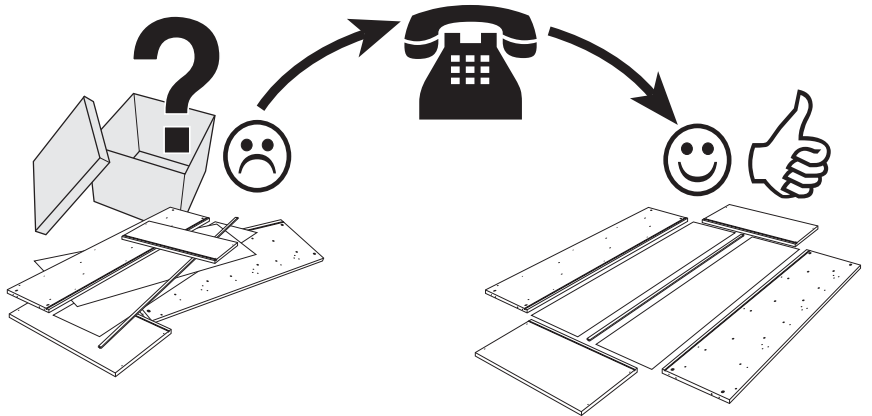
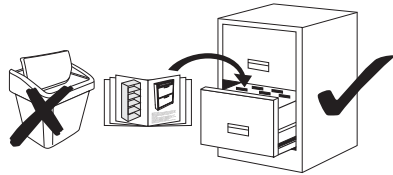

Detail specification

A.i. Nr.	Article Nr.	pcs
①	013001-32	x2
②	013002-32	x2
③	013003-32	x2
④	013004-32	x2
⑥	013112-32	x4
⑩	108821-00	x16
⑤②	013114-00	x1
⑤③	013113-32	x2

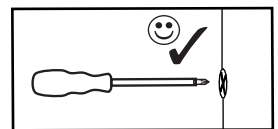
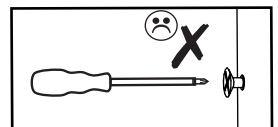
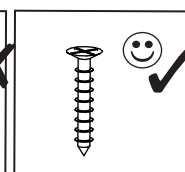
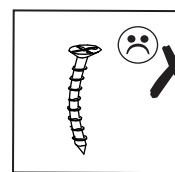
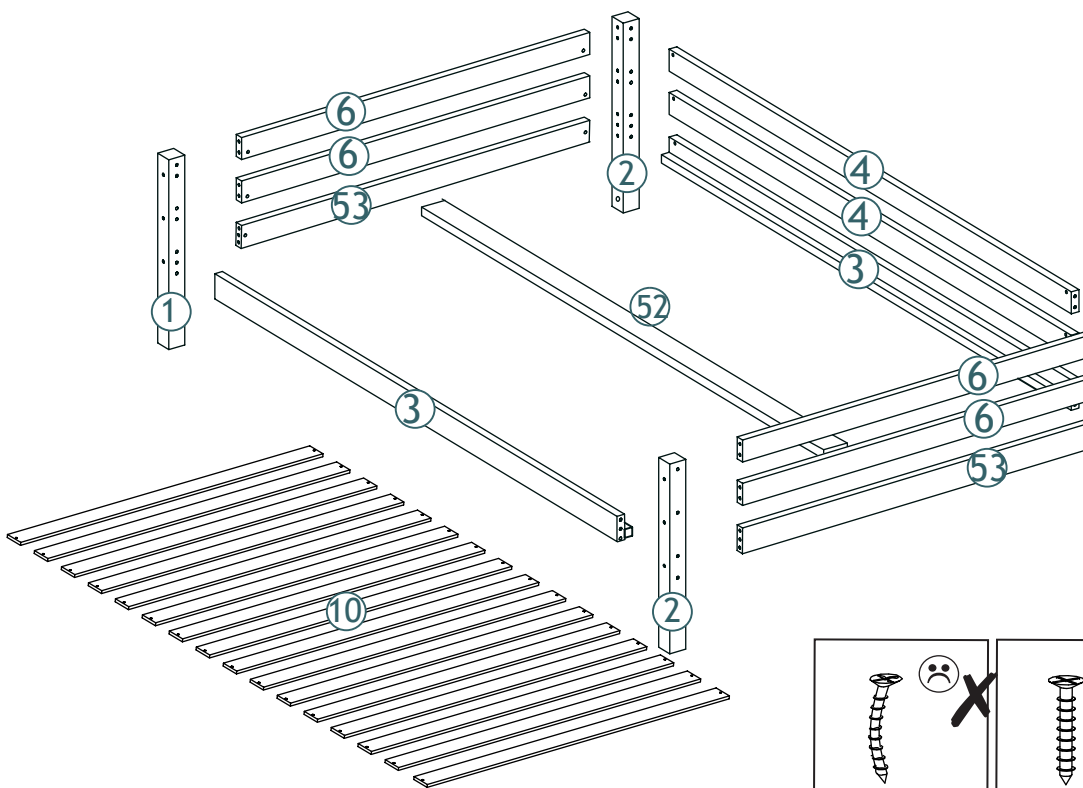

Fitting specification

A.i. Nr.	Article Nr.	Dimensions	pcs
a	1-000011-07	10x18	x24
b	1-000010-07	M6x100	x24
c	1-000013-00	8x40	x24
d	1-000012-07	3x30	x32
e	1-000014-57	8x13	x12
f	1-000015-07	Z4	x1
g	1-000016-57	16x10	x4
h	1-000114-09	8x13	x2
i	1-000115-07	3,5x15	x14

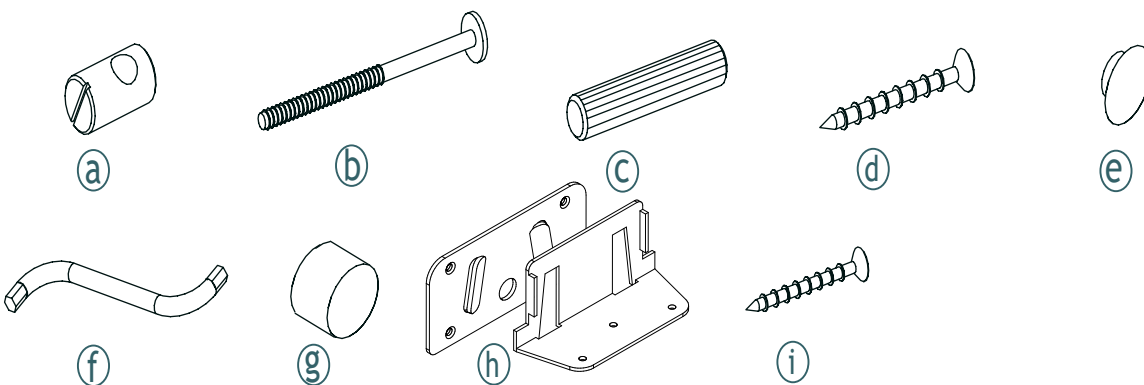

Make sure that there are no loose and leave screws!
Stellen Sie sicher, dass keine losen Schrauben und verlassen!
Zorg ervoor dat er geen losse en laat schroeven!
Assurez-vous qu'il n'y a pas lâches et laissent vis!

1-000001=

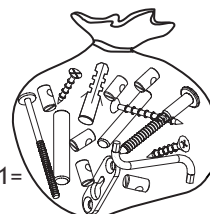

1.

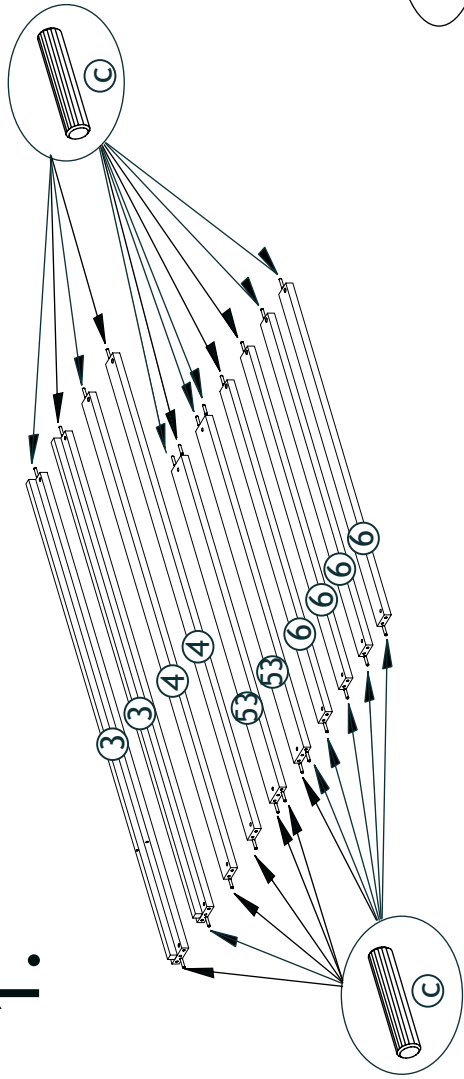

2.

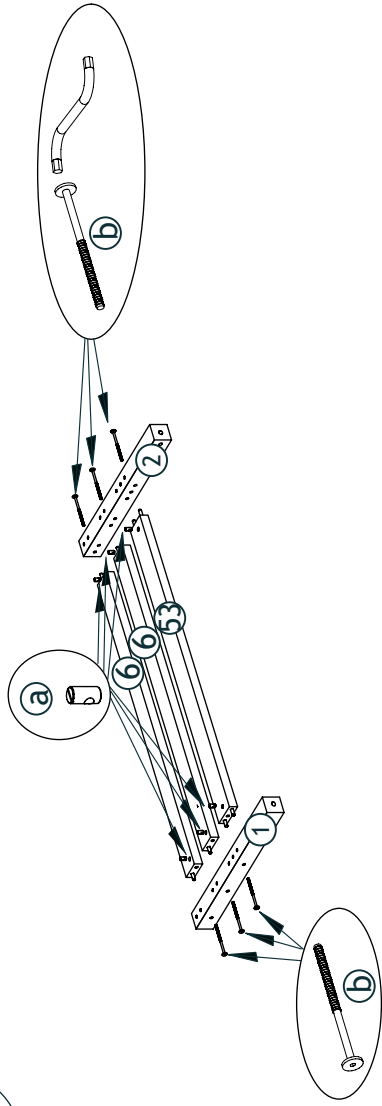

3.

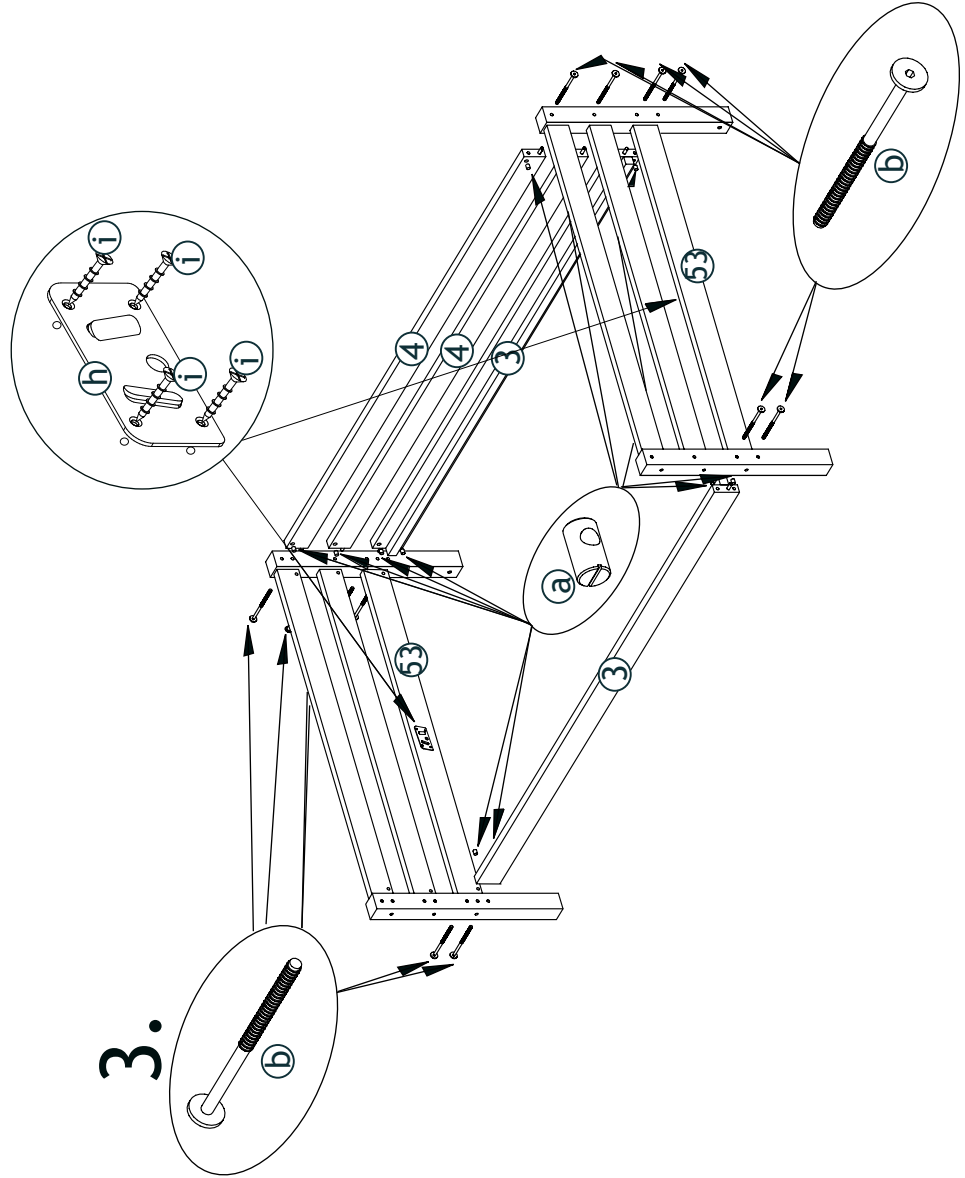

4.

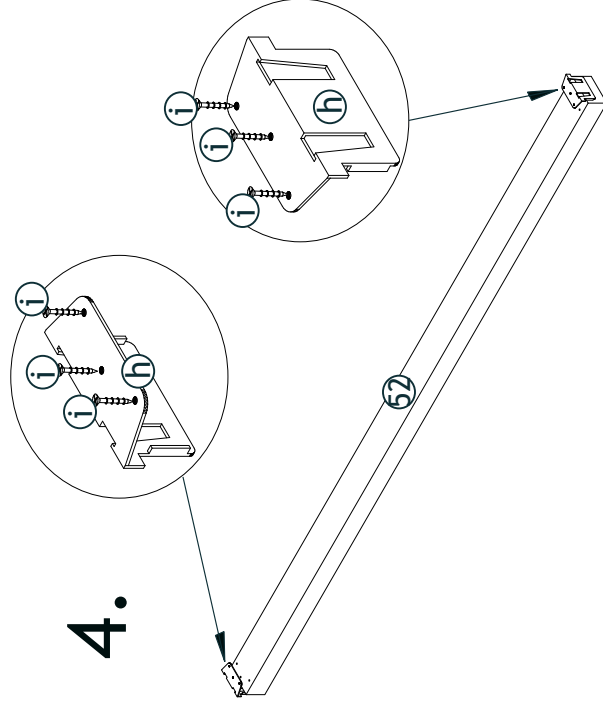

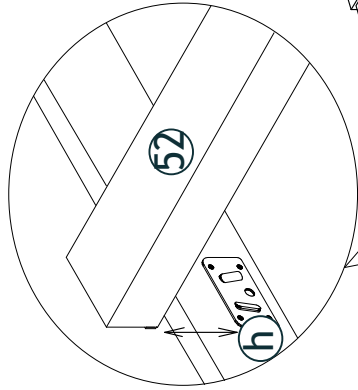

5.

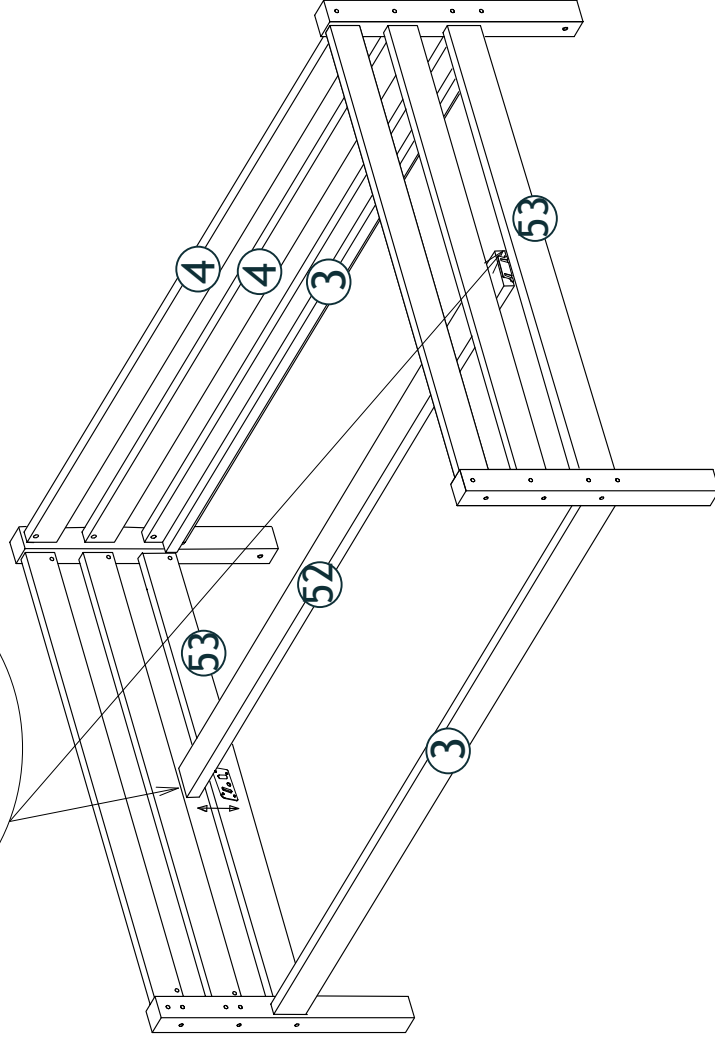

6.

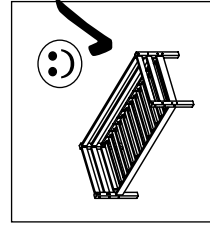
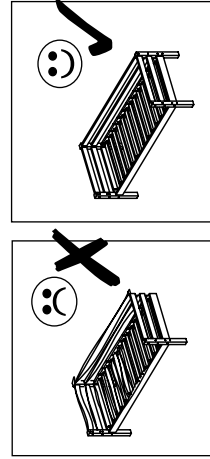
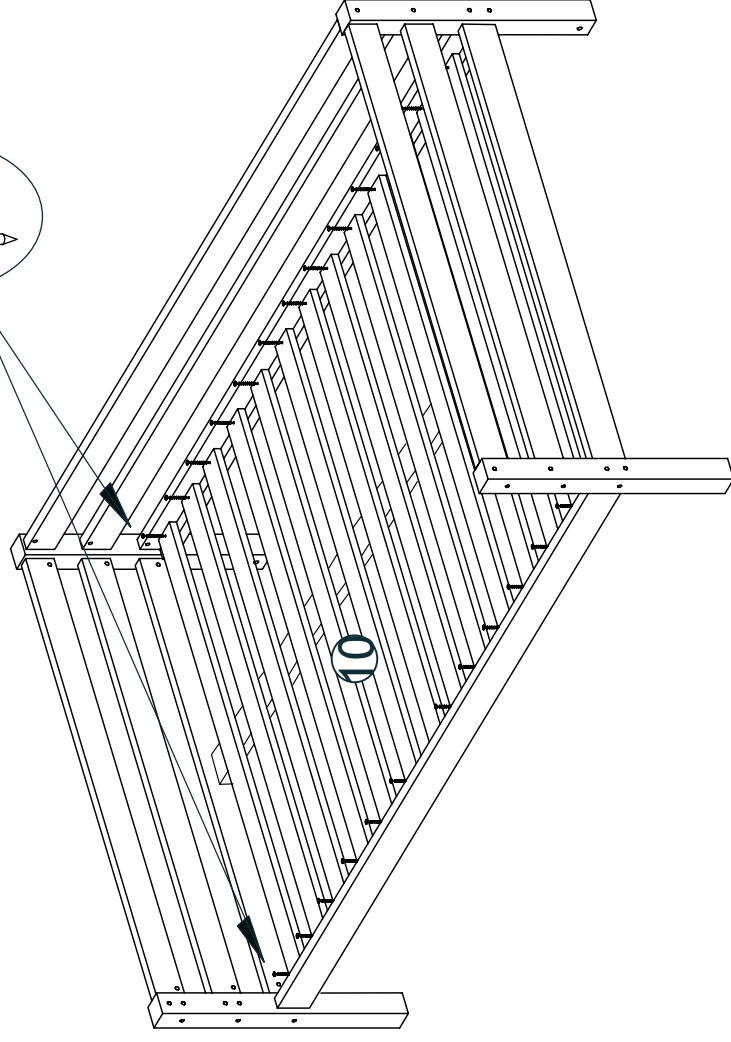
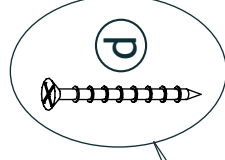

Empfohlene Matratzengröße 90mm!
 Recommended mattress thickness 90mm!
 Anbefalet madrass tykkelse 90mm!
 épaisseur de matelas recommandée 90mm

Close free holes with caps
 Luk alle huller med propper
 Schliessen Sie die offenen Löcher mit den Deckkappen
 Fermez les trous découverts avec les chapes

Ⓛ Aufbauanleitung

Ⓛ Notice de montage

Ⓛ Montagehandleiding

Ⓛ Montážní návod

Ⓛ Szerelési útmutató

Ⓛ Montaj talimatları

Ⓛ Assembly instruction

Ⓛ Istruzione di montaggio

Ⓛ Instrukcja montażu

Ⓛ Navod na montaž

Ⓛ Instrucțiuni de montaj

Ⓛ Инструкция по монтажу

37-0002-32-200

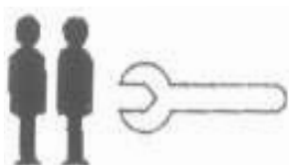
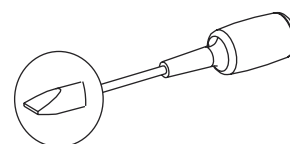
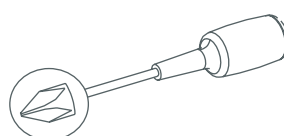
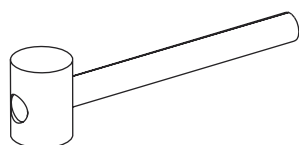
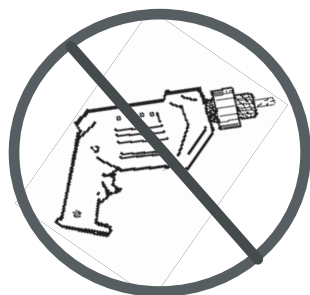
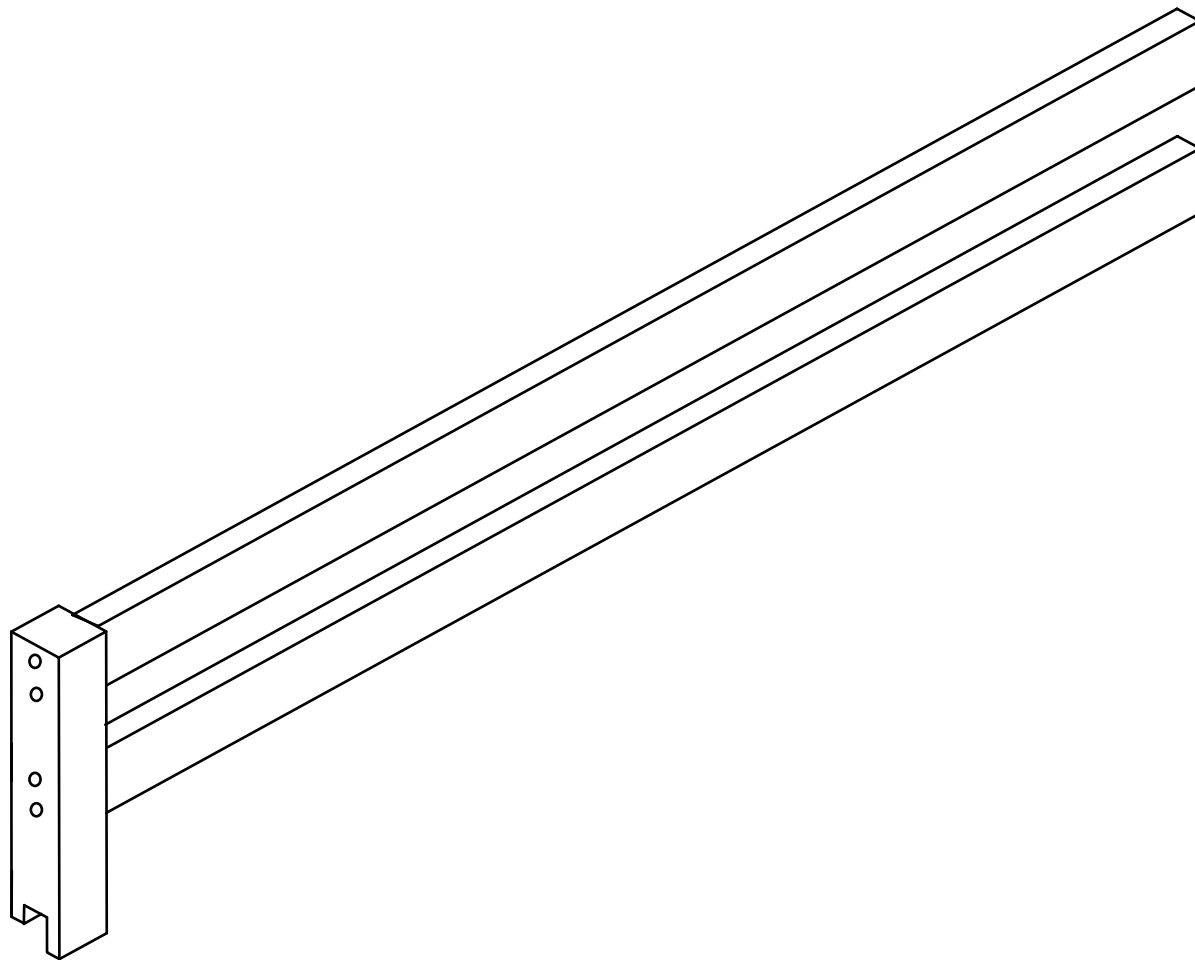

DIN EN 747-1:2015
DIN EN 747-2:2015



Service • Assistenza • Dienstverlening • Serwis Servis • Szerviz • Сервисная служба

Name • Nom • Nome • Naam • Nazwa • Jméno • Názov
Név • Denumire • Isim • Название

Nr. • No. • N° • Č • Sz • Номер

Typ • Type • Tip • Tipus • Druh • Тіро • Тип

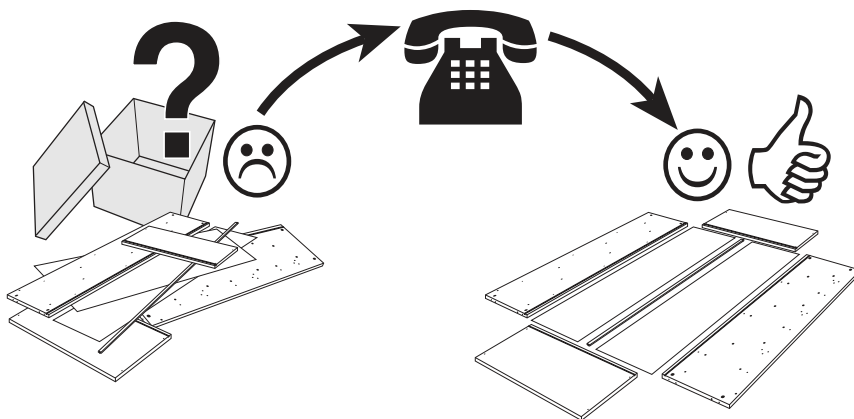
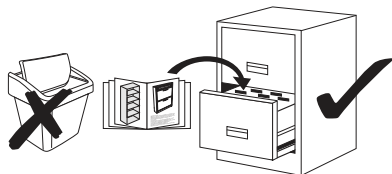

Detail specification

A.i. Nr.	Article Nr.	pcs
7	013007-32	x1
8	013008-32	x2

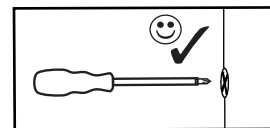
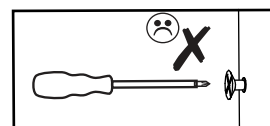
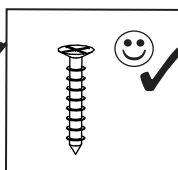
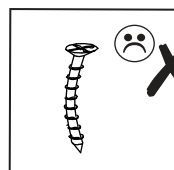
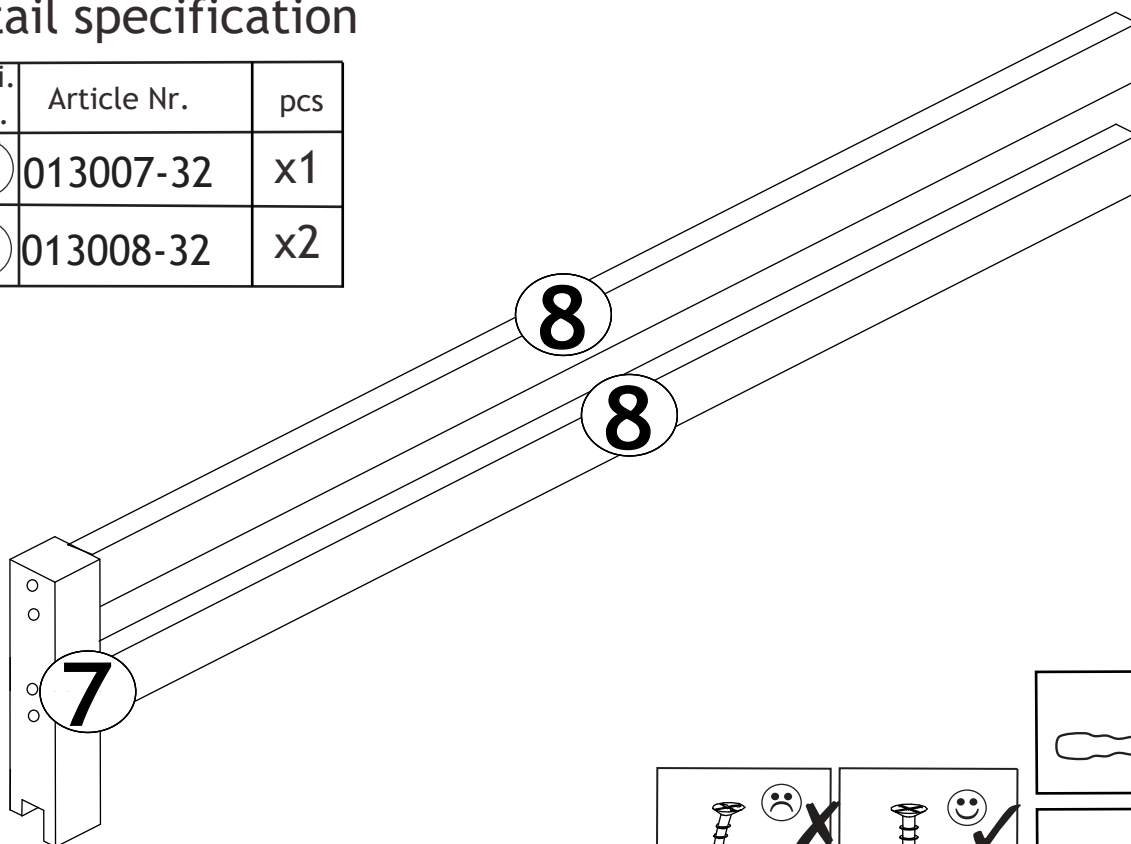

h



i

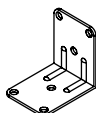

j



c

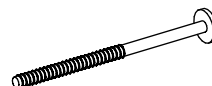

b



a



e



g

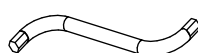

f

Fitting specification

A.i. Nr.	Article Nr.	Dimensions	pcs
h	1-000020-07	3,5x25	x3
i	1-000019-07	3,5x15	x4
j	1-000018-07	48x40x2,5	x1
c	1-000013-00	8x40	x4
b	1-000010-07	M6x100	x4
a	1-000011-07	M6x10/18	x4
e	1-000014-57	6x8	x2
g	1-000017-07	45x45x2	x1
f	1-000015-07	Z4	x1

1-000001=

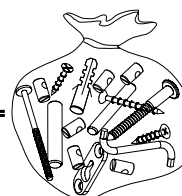

37-0001+37-0002

1.

2.

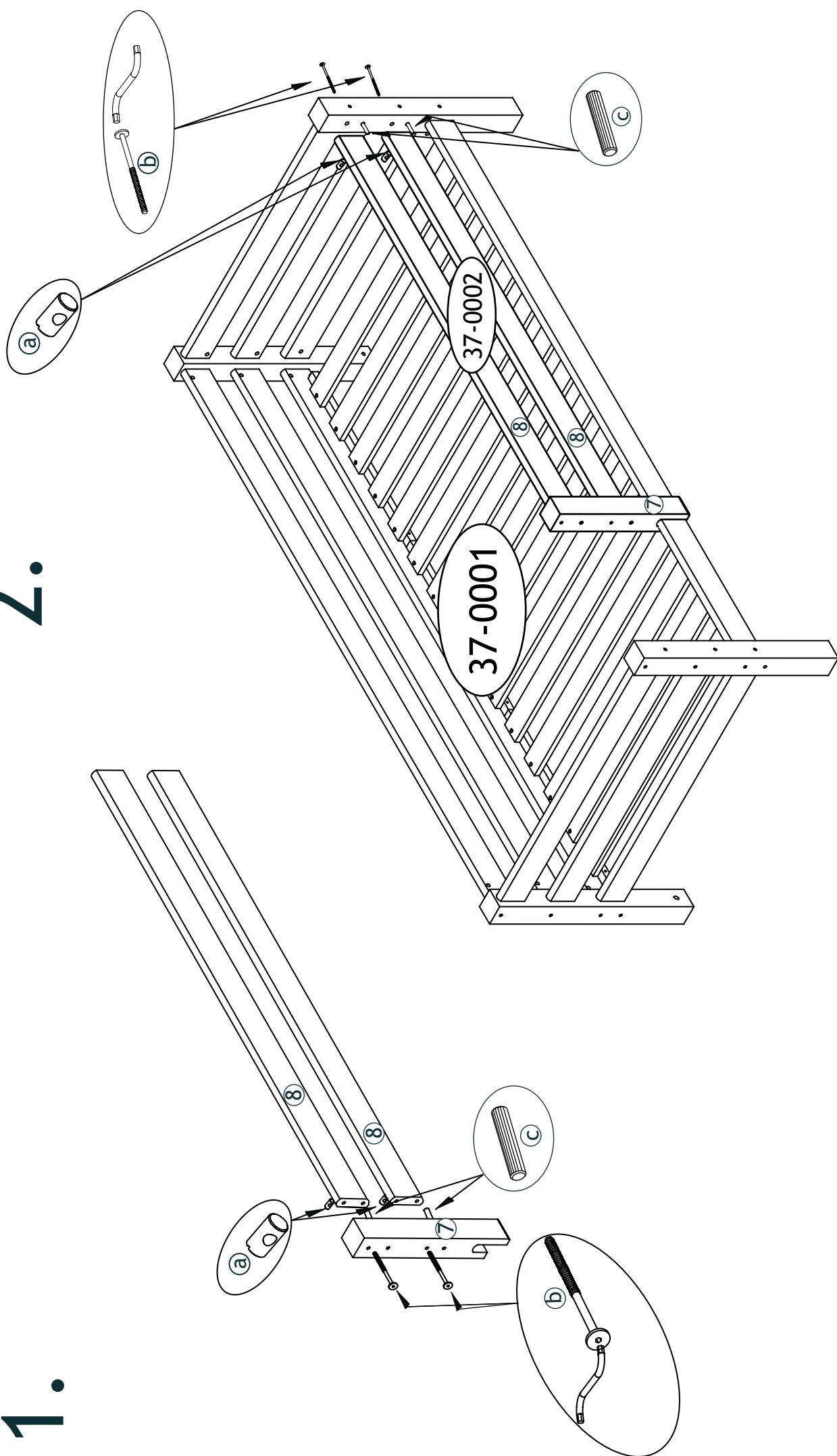

3.

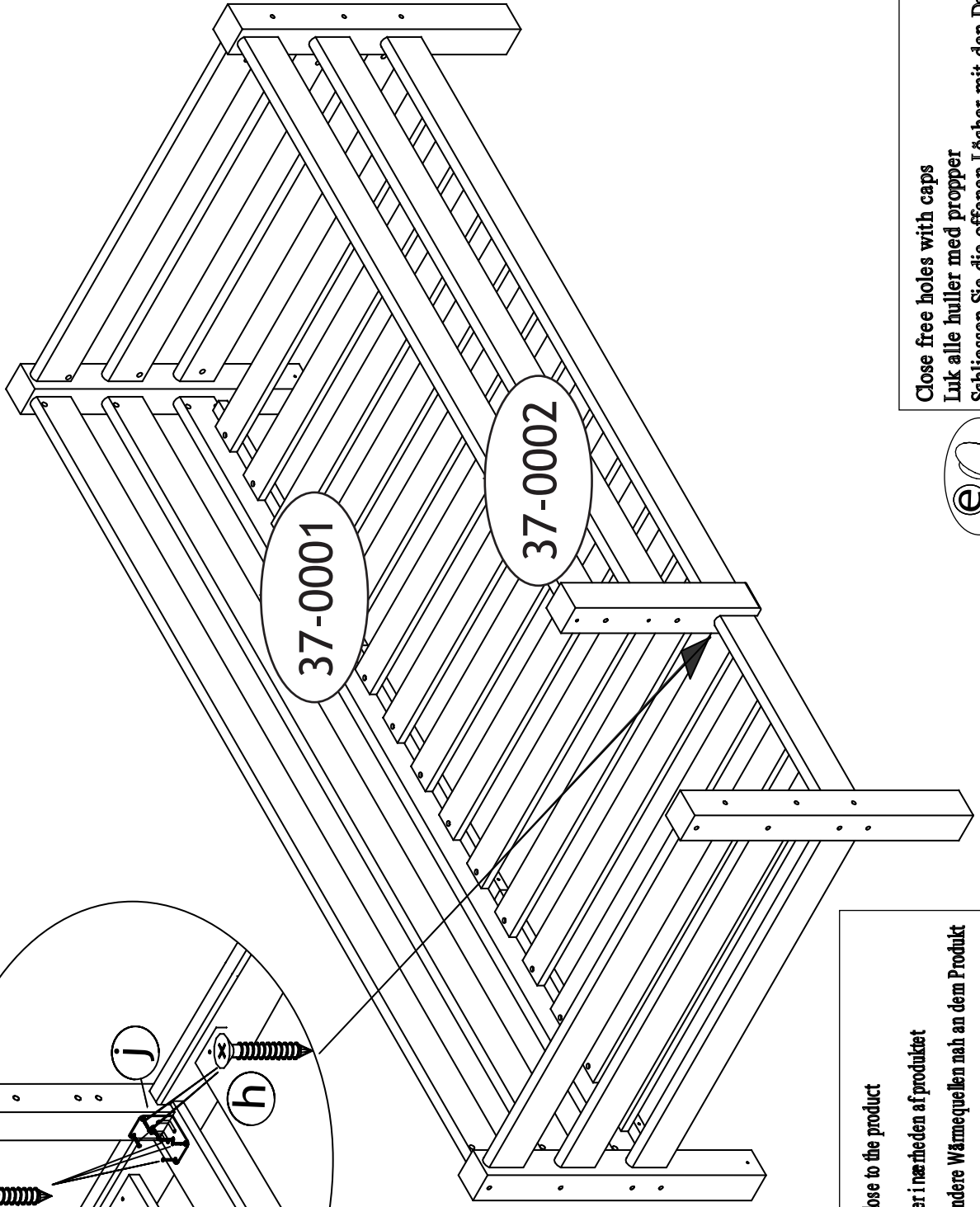
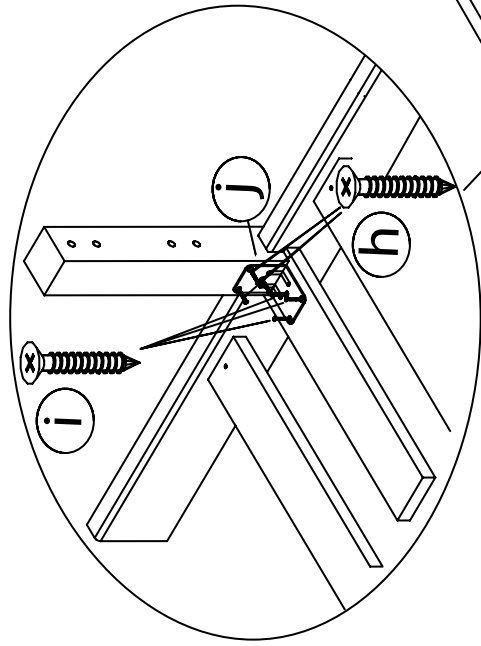

- (UK)** Be aware of the risk of open fire and other heating sources close to the product
- (DK)** Vær opmærksom på risikoen for åben ild og andre varmekilder i nærheden af produktet
- (DE)** Berücksichtigen Sie die Gefahr des geöffneten Feuers und andere Wärmequellen nah an dem Produkt
- (FR)** Ne pas placer le produit à proximité du feu ou du chauffage puissant

Close free holes with caps
Luk alle huller med propper
Schliessen Sie die offenen Löcher mit den Deckkappen
Fermez les trous découverts avec les chapes



37-0017+37-0002

1.

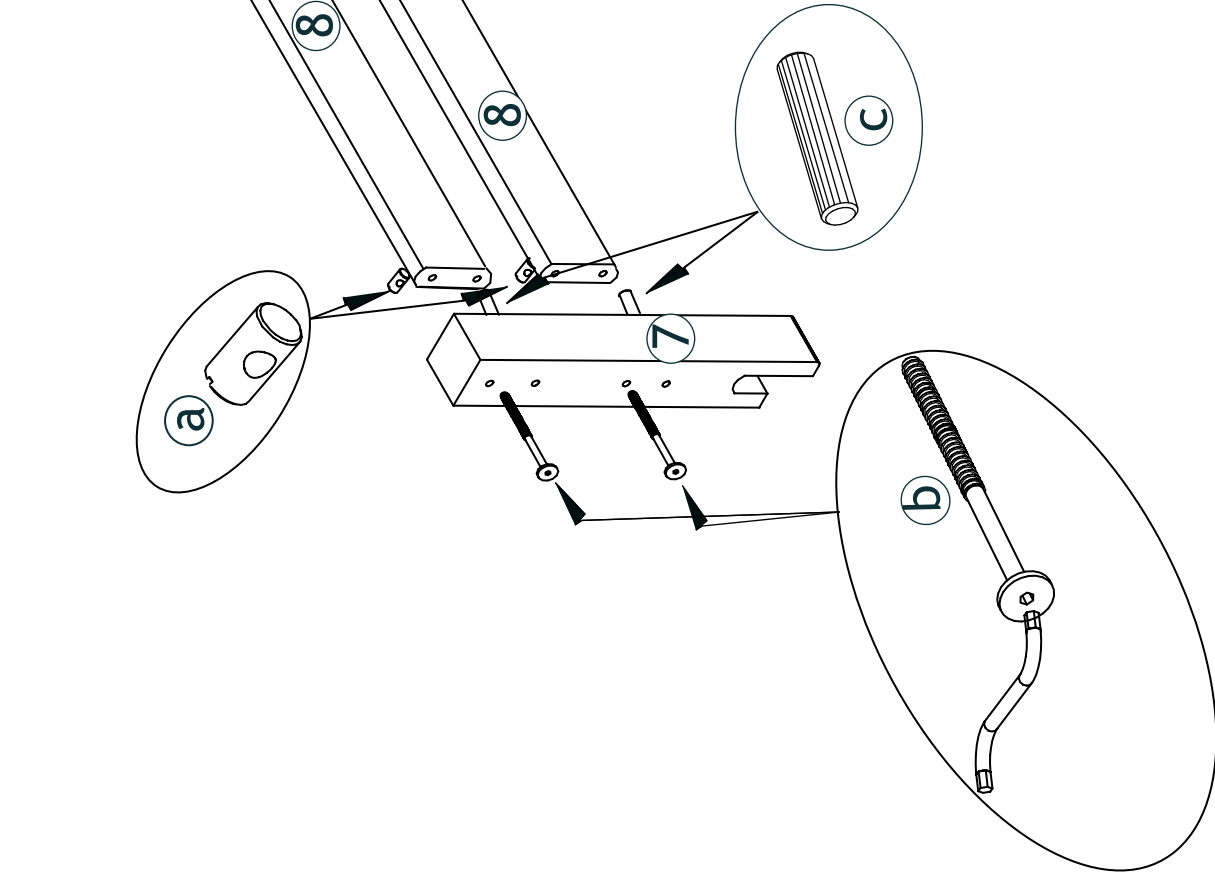

2.

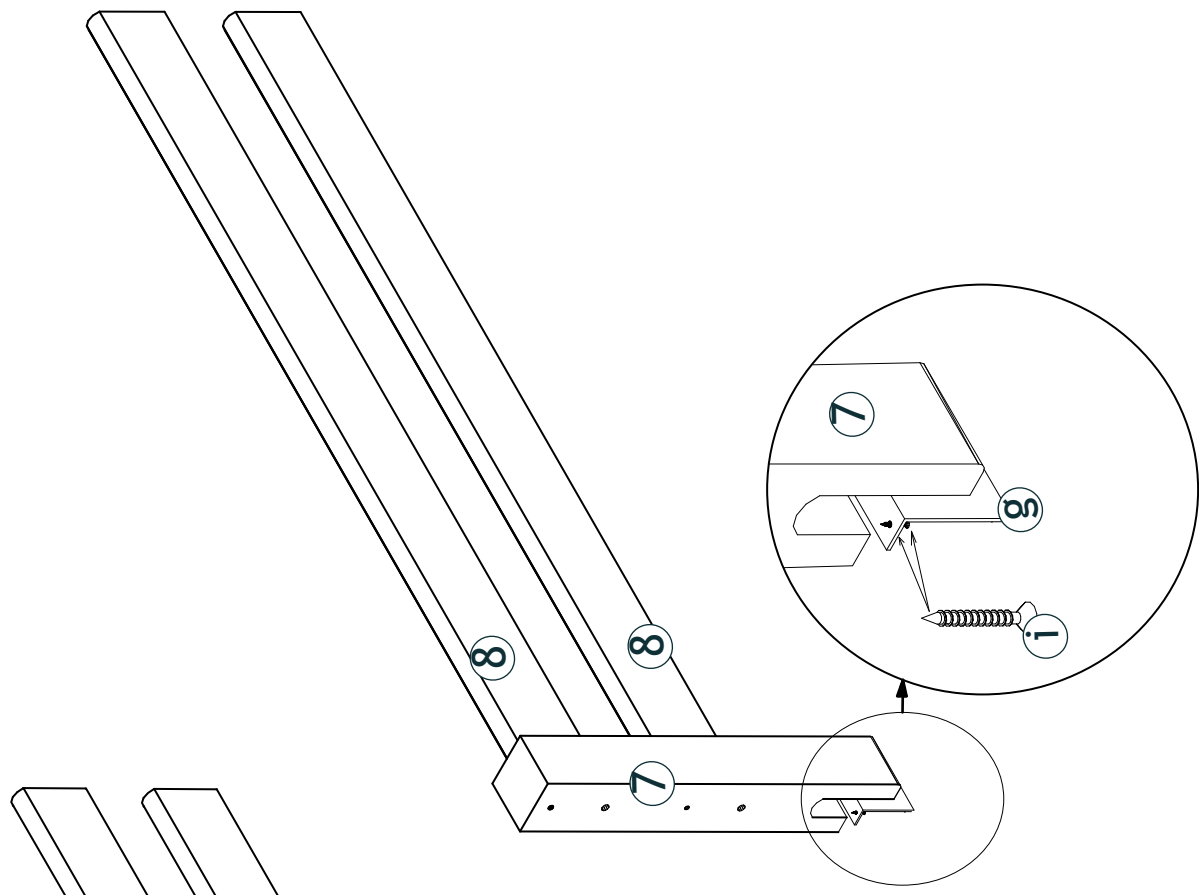

3.

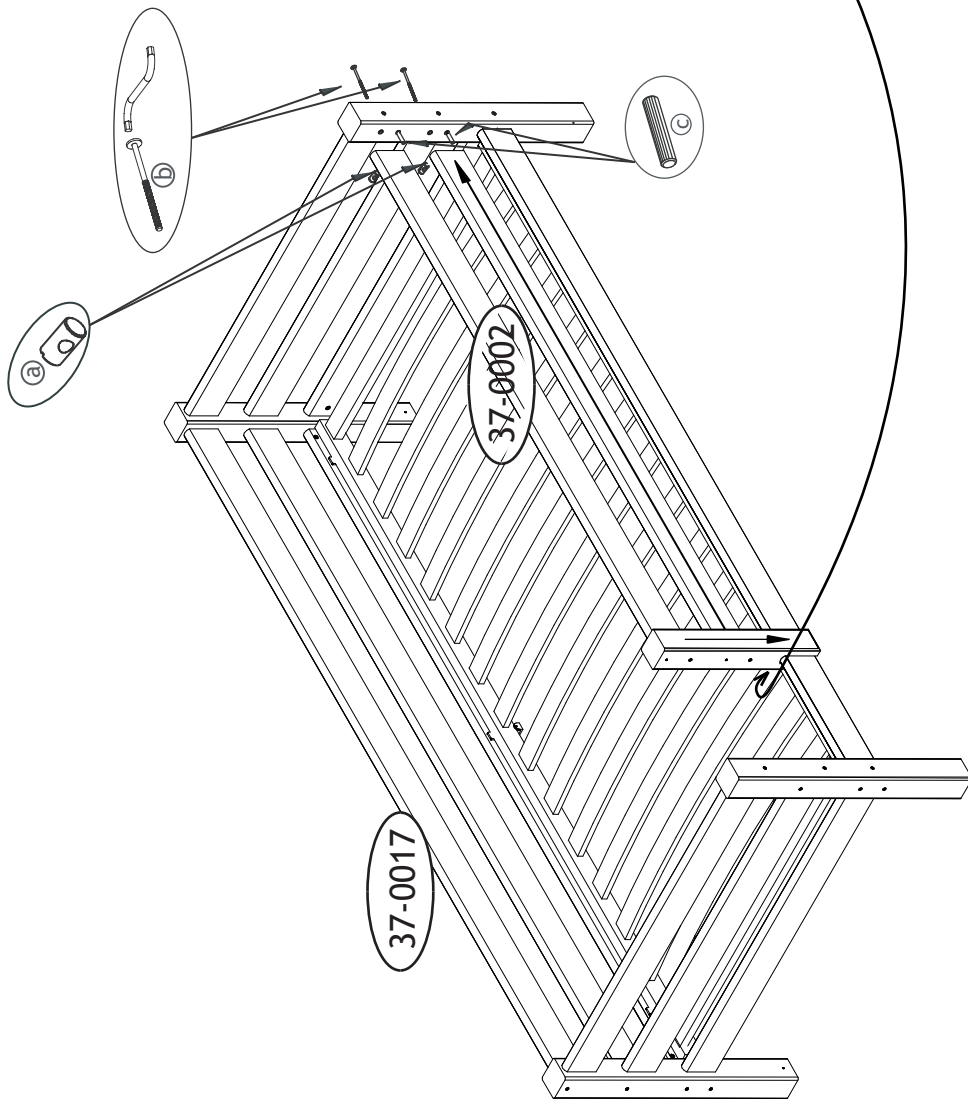

4.

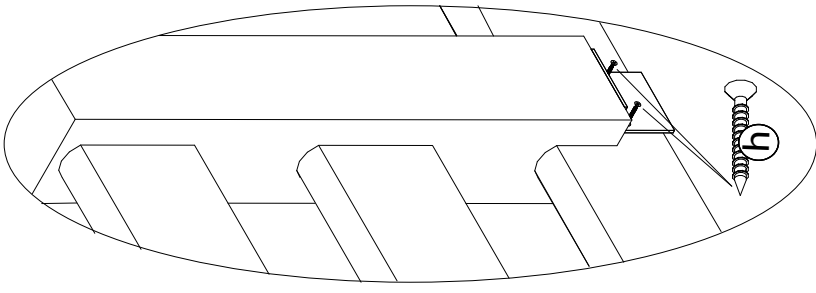

(UK) - Be aware of the risk of open fire and other heating sources close to the product
(DK) - Vær opmærksom på risikoen for åben ild og andre varmekilder i nærheden af produktet
(DE) - Berücksichtigen Sie die Gefahr des geöffneten Feuers und andere Wärmequellen nah an dem Produkt
(FR) - Ne pas placer le produit à proximité du feu ou du chauffage puissant

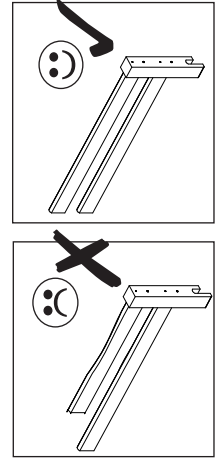

Close free holes with caps
Luk alle huller med propper
Schliessen Sie die offenen Löcher mit den Deckkappen
Fermez les trous découverts avec les chapes



Ⓓ Aufbauanleitung

Ⓕ Notice de montage

Ⓖ Montagehandleiding

Ⓒ Montážní návod

Ⓗ Szerelési útmutató

Ⓙ Montaj talimatları

Ⓖ Assembly instruction

Ⓙ Istruzione di montaggio

Ⓙ Instrukcja montażu

Ⓙ Navod na montaž

Ⓙ Instrucțiuni de montaj

Ⓙ Инструкция по монтажу

37-0036-32-12A

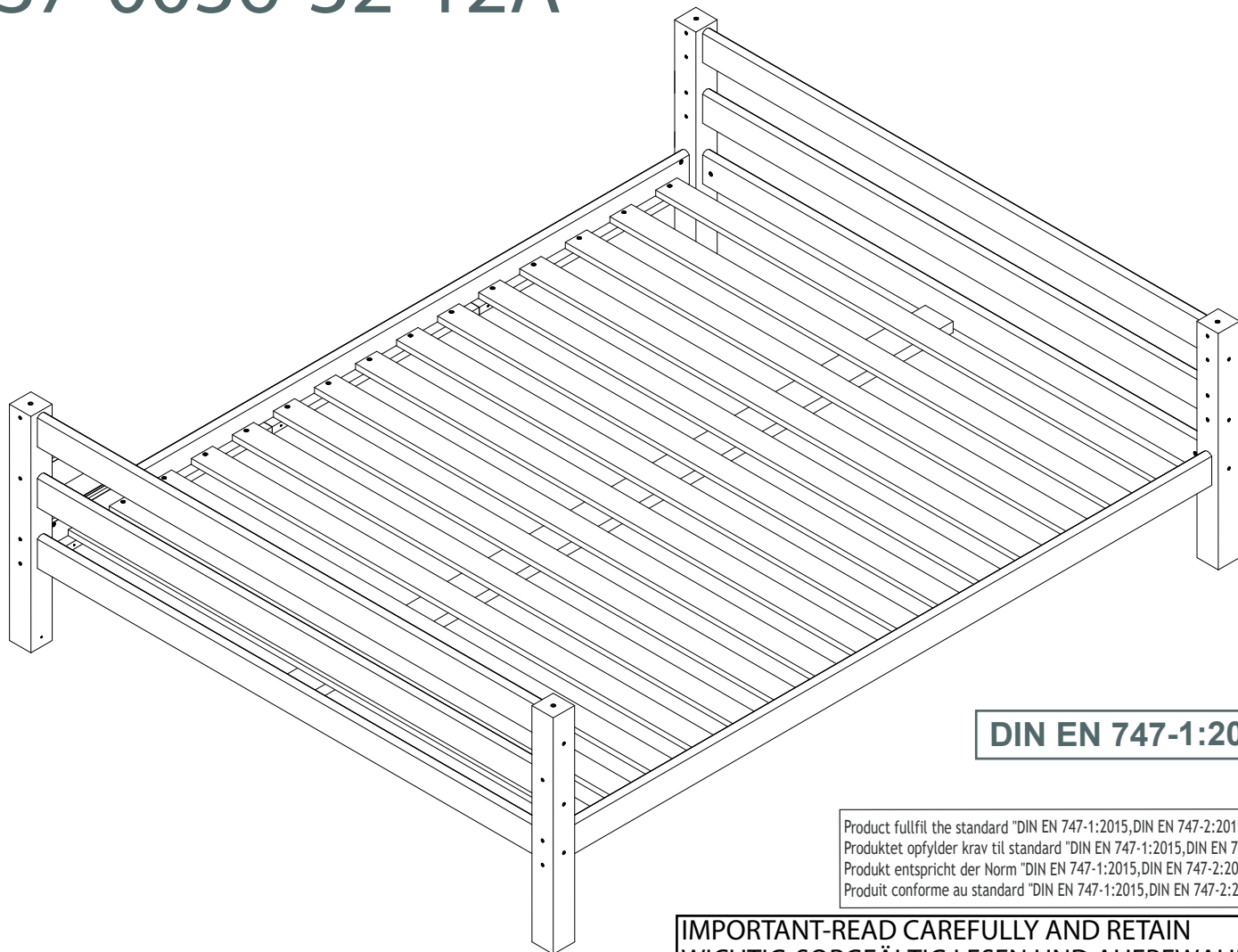

DIN EN 747-1:2015

Product fulfill the standard "DIN EN 747-1:2015,DIN EN 747-2:2015"
Produktet opfylder krav til standard "DIN EN 747-1:2015,DIN EN 747-2:2015"
Produkt entspricht der Norm "DIN EN 747-1:2015,DIN EN 747-2:2015"
Produit conforme au standard "DIN EN 747-1:2015,DIN EN 747-2:2015"

**IMPORTANT-READ CAREFULLY AND RETAIN
WICHTIG-SORGFÄLTIG LESEN UND AUFBEWAHREN
VIGTIGT-LÆS grundigt igennem og opbevar
IMPORTANT-LIRE ATTENTIVEMENT ET A CONSERVER**

Ⓓ Werkzeuge, die Sie Brauchen werden.

Ⓖ Tools you will need.

Ⓕ Outils nécessaires

Ⓙ Værktøj som er nødvendigt.

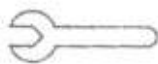
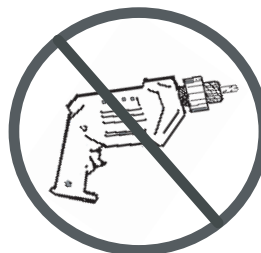
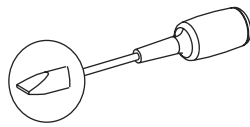
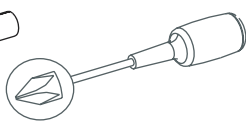
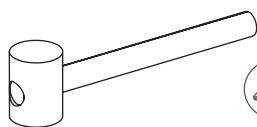

Ⓓ Wir empfehlen, dass zwei Personen sich bei der Montage beteiligen.

Ⓖ It is advisory to be two people during assembly.

Ⓕ Nous vous conseillons d'être à deux personnes pour le montage.

Ⓙ Vi anbefaler, at man er to personer om at samle.

SERVICEKARTE

Modellname:	Artikel - Nr.:	Type: (falls vorhanden)	Farb - Nr.: (falls vorhanden)
-------------	----------------	-------------------------	-------------------------------

Lie be Kundin, lieber Kunde, obwohl wir unsere Möbel vor der Auslieferung einer eingehenden Endkontrolle unterziehen, kann es vorkommen, dass einmal ein Zubehörteil fehlt oder dass ein Teil während des Transports beschädigt wird. Senden Sie den Artikel in so einem Fall bitte nicht zurück, sondern fordern Sie einfach Ersatz für das fehlende bzw. beschädigte Teil unserer Kunden-Hotline an. Die Telefonnummer finden Sie auf den Serviceseiten im aktuellen Katalog. Bitte nennen Sie bei der Ersatzteilbestellung Modellnamen, Artikelnummer, Type und Farbnummer des Möbelstückes sowie die benötigten Ersatzteilnummern/-bezeichnungen, wie sie in dieser Anleitung angegeben sind. Wir werden Ihre Anforderung sofort bearbeiten und Ihnen das Ersatzteil umgehend zusenden.

Detail specification

A.i. Nr.	Article Nr.	pcs
61	013061-32	x2
62	013062-32	x2
3	013003-32	x2
6	013112-32	x4
10	108821-00	x16
52	013114-00	x1
53	013113-32	x2

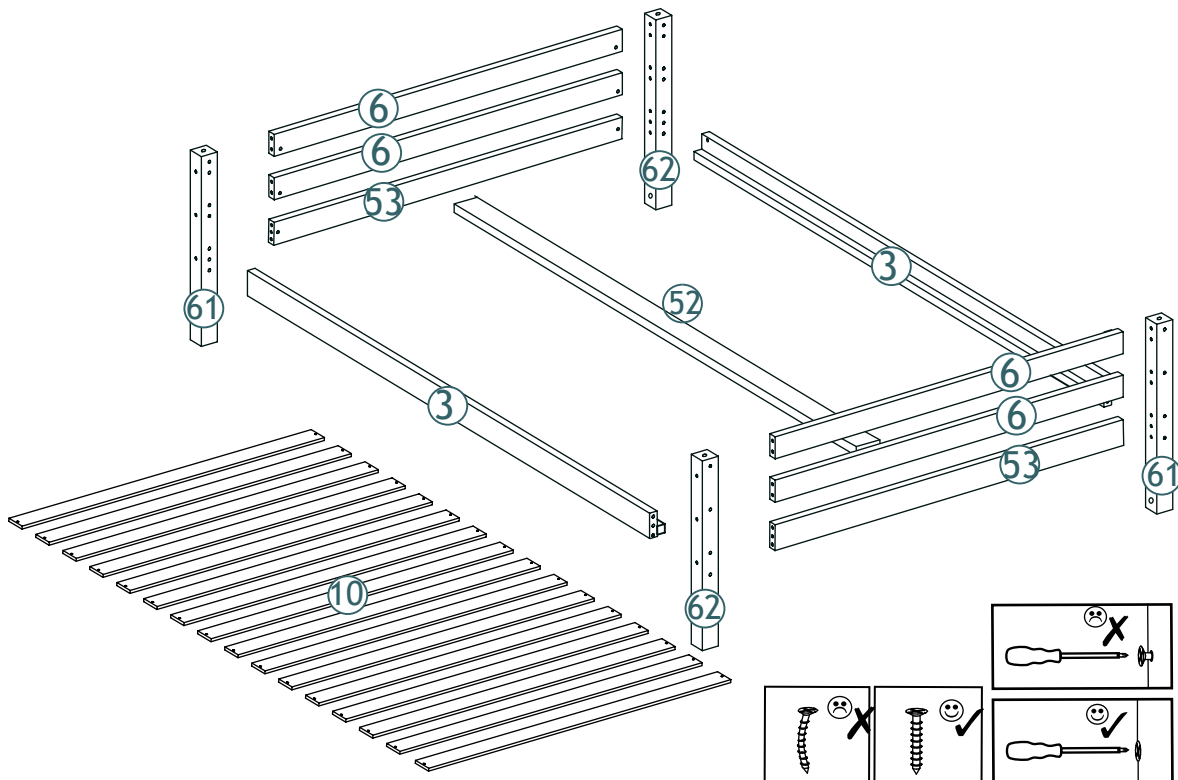

DE Überprüfungliste für Zubehör;
 UK Fittings checklist;
 FR Accessoiresliste de vérification.
 DK Checkliste for beslag;

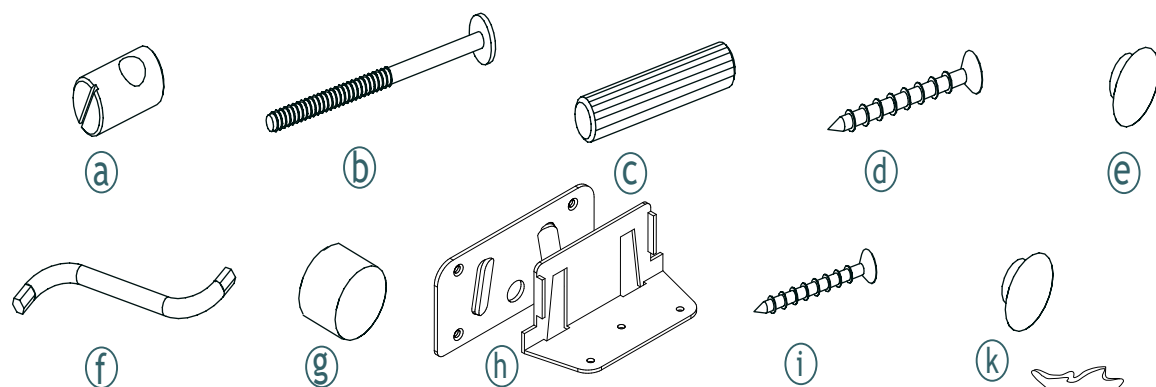

Fitting specification

A.i. Nr.	Article Nr.	Dimensions	pcs
a	1-000011-07	10x18	x20
b	1-000010-07	M6x100	x20
c	1-000013-00	8x40	x20
d	1-000012-07	3x30	x32
e	1-000014-57	8x13	x24
f	1-000015-07	Z4	x1
g	1-000016-57	16x10	x4
h	1-000114-09	8x13	x2
i	1-000115-07	3,5x15	x14
k	1-000170-57	10x15	x4

Hier können Sie die Schrauben zur besseren Identifizierung nachmessen.



1-000001=

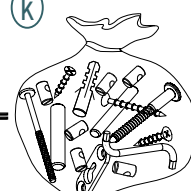

Bitte füllen Sie diese Servicekarte sorgfältig aus, damit Sie alle nötigen Daten bei Ihrer Ersatzteilbestellung zur Hand haben. Die Telefonnummer der Bestellannahme finden Sie in Ihrem aktuellen Katalog.

Modellname: ;
 Artikel - Nr: ;
 Type: ;
 Farb - Nr: ;
 Kundennummer: ;
 Name: ;
 Strasse:..... Haus - Nr: ;
 PLZ:..... Ort:..... ;
 Rechnungsdatum: ;

Tel. für Rückfragen: ;
 Grund der Ersatzteilanforderung: ;

Benötigte Teile:

Teile-Nr	Bezeichnung	Anzahl

1.

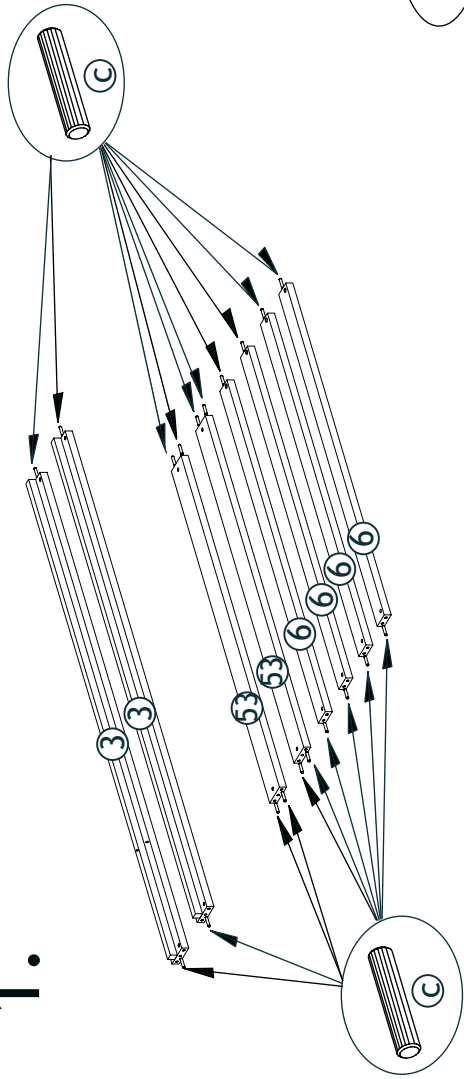

2.

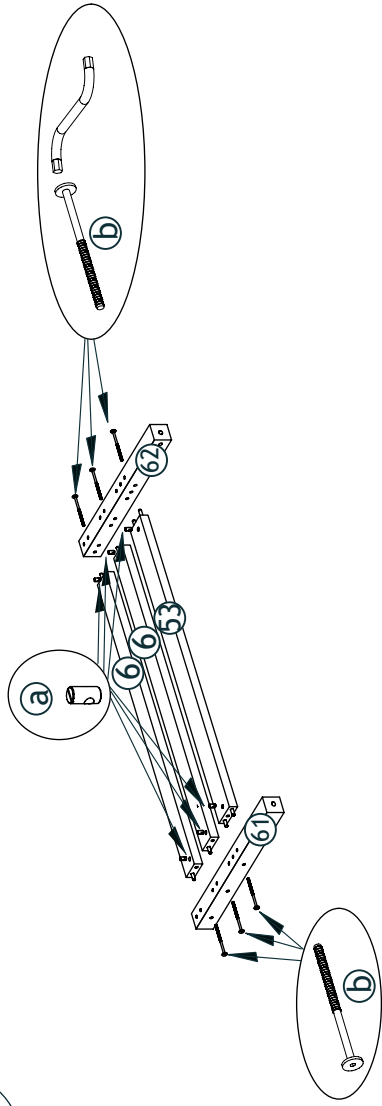

3.

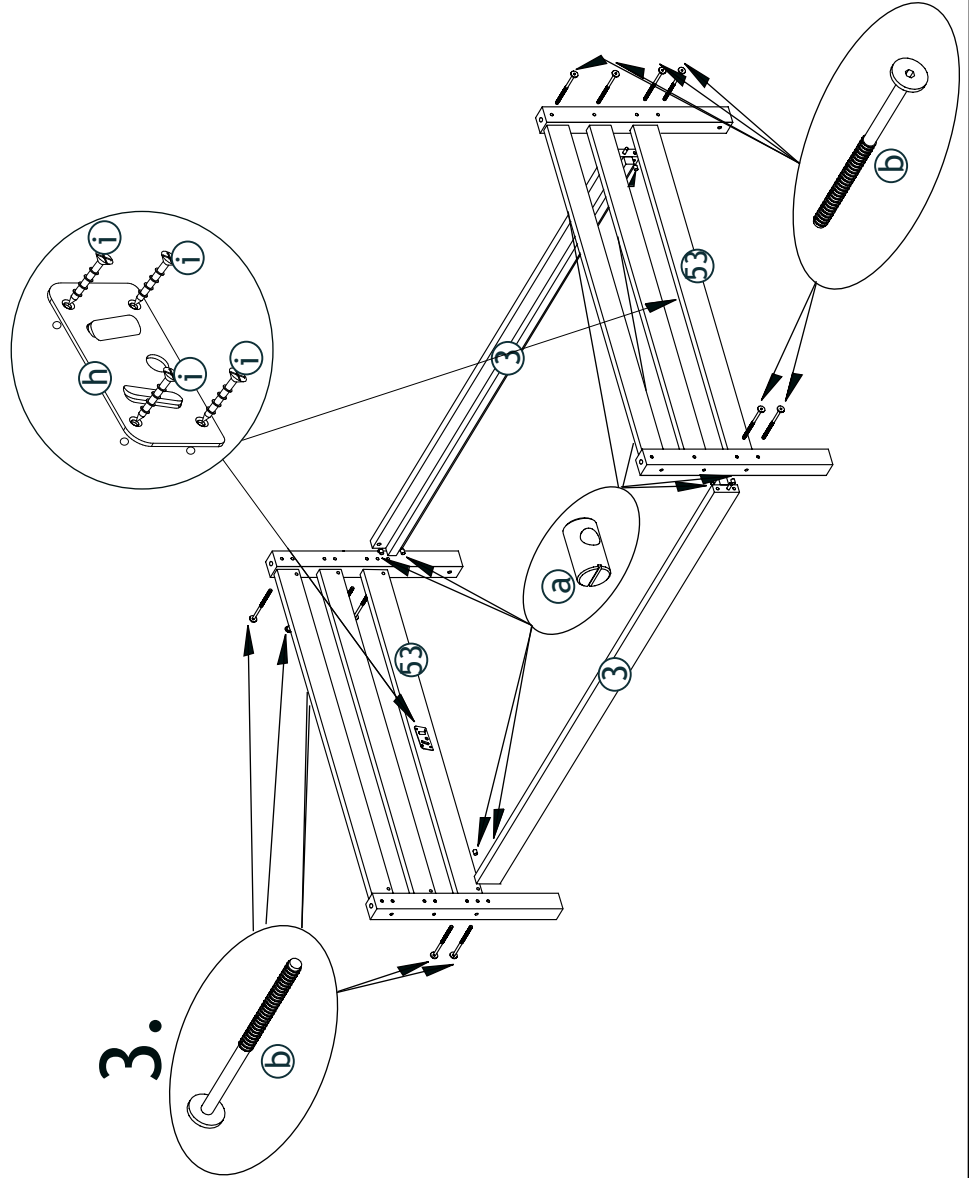

4.

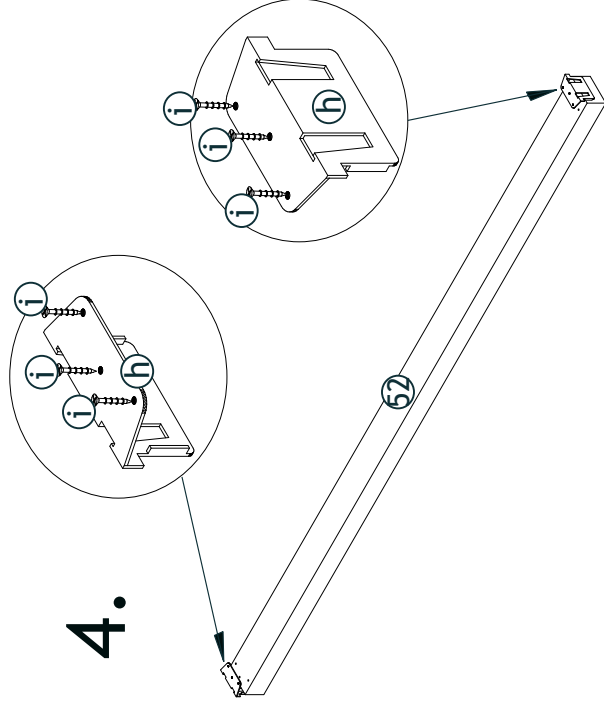

6.

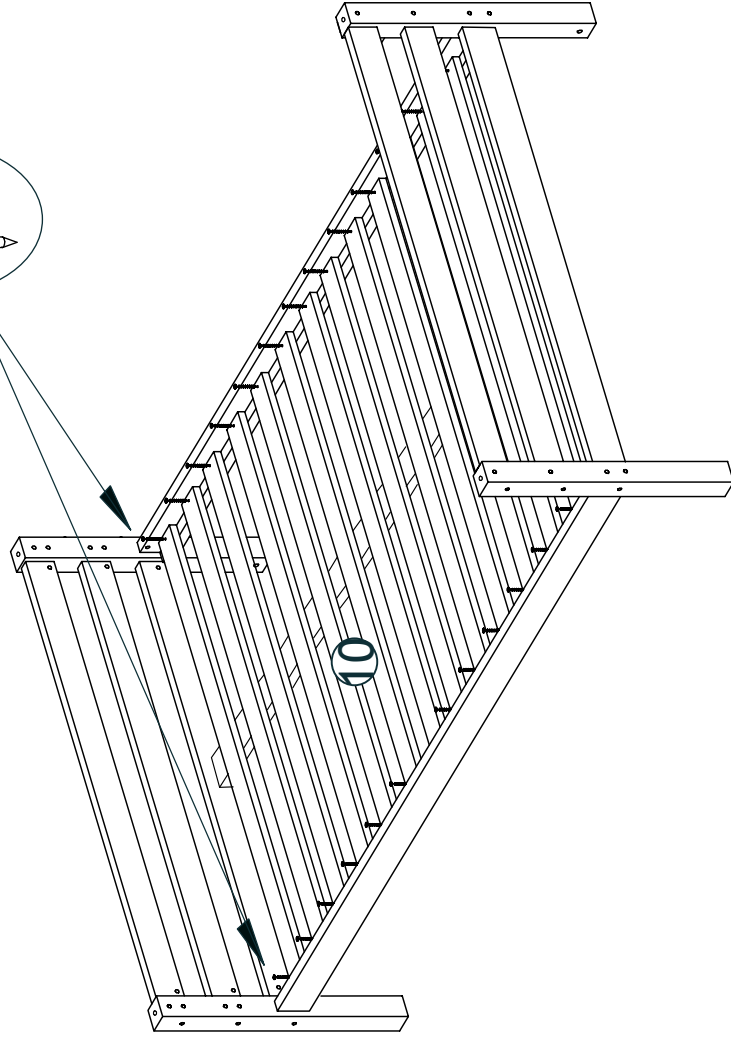
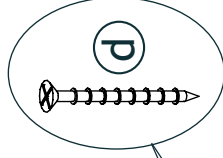

Empfohlene Matratzengröße 90mm!
 Recommended mattress thickness 90mm!
 Anbefalet madrass tykkelse 90mm!
 épaisseur de matelas recommandée 90mm

Close free holes with caps
 Luk alle huller med propper
 Schliessen Sie die offenen Löcher mit den Deckkappen
 Fermez les trous découverts avec les chapes

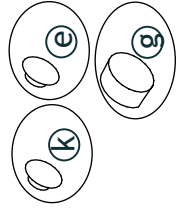

5.

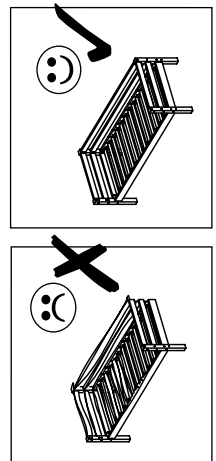
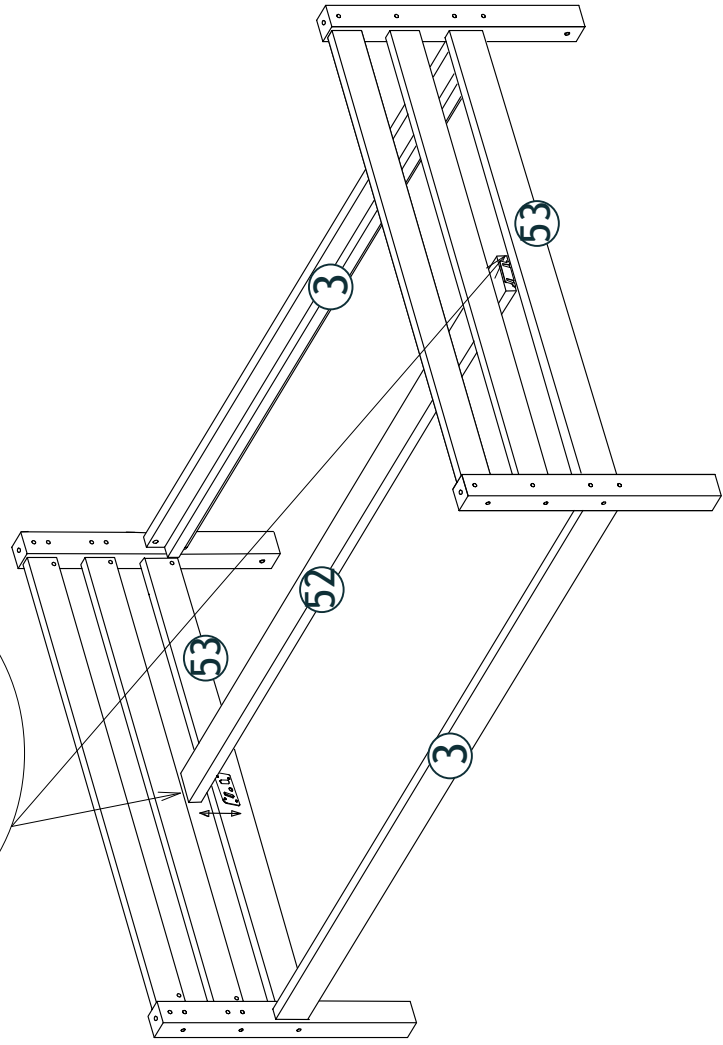
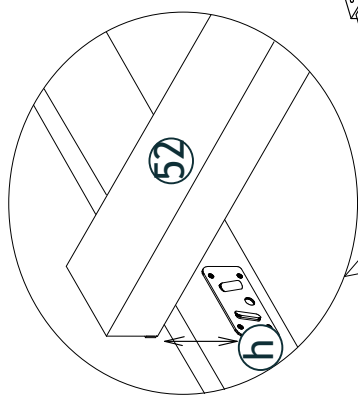

Aufbauanleitung

37-0013-32-200

Sicherheit Schiene

Safety Boards

Sengehest

Sécurité Rail

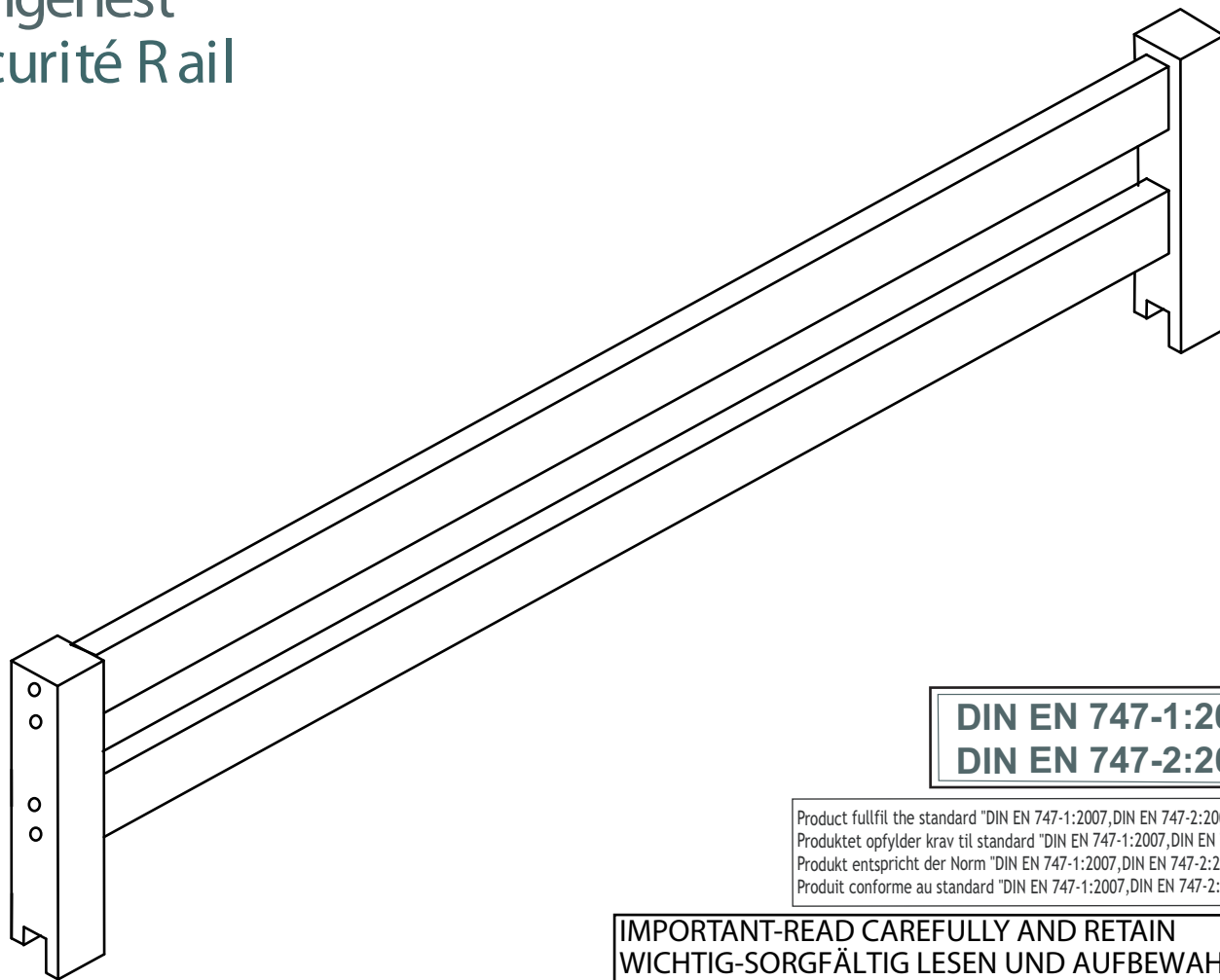

DIN EN 747-1:2007
DIN EN 747-2:2007

Product fullfil the standard "DIN EN 747-1:2007,DIN EN 747-2:2007"
Produktet opfylder krav til standard "DIN EN 747-1:2007,DIN EN 747-2:2007"
Produkt entspricht der Norm "DIN EN 747-1:2007,DIN EN 747-2:2007"
Produit conforme au standard "DIN EN 747-1:2007,DIN EN 747-2:2007"

IMPORTANT-READ CAREFULLY AND RETAIN
WICHTIG-SORGFÄLTIG LESEN UND AUFBEWAHREN
VIGTIGT-LÆS grundigt igennem og opbevar
IMPORTANT-LIRE ATTENTIVEMENT ET A CONSERVER

DE Werkzeuge, die Sie Brauchen werden. **UK** Tools you will need. **FR** Outils nécessaires **DK** Værktøj som er nødvendigt.

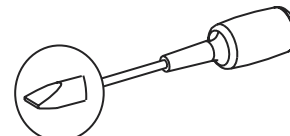
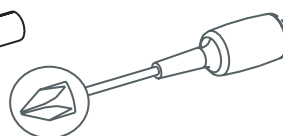
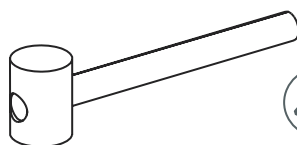
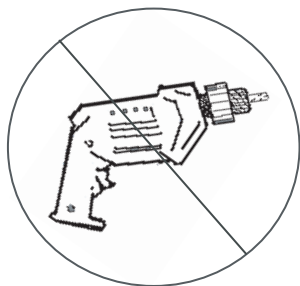

DE Wir empfehlen, dass zwei Personen sich bei der Montage beteiligen.

UK It is advisory to be two people during assembly.

FR Nous vous conseillons d'être à deux personnes pour le montage.

DK Vi anbefaler, at man er to personer om at samle.

SERVICEKARTE

Modellname:	Artikel - Nr.:	Type: (falls vorhanden)	Farb - Nr.: (falls vorhanden)
-------------	----------------	-------------------------	-------------------------------

Detail specification

A.i. Nr.	Article Nr.	pcs
7	013007-32	x2
25	013024-32	x2

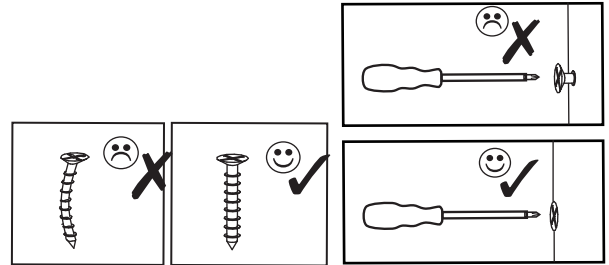
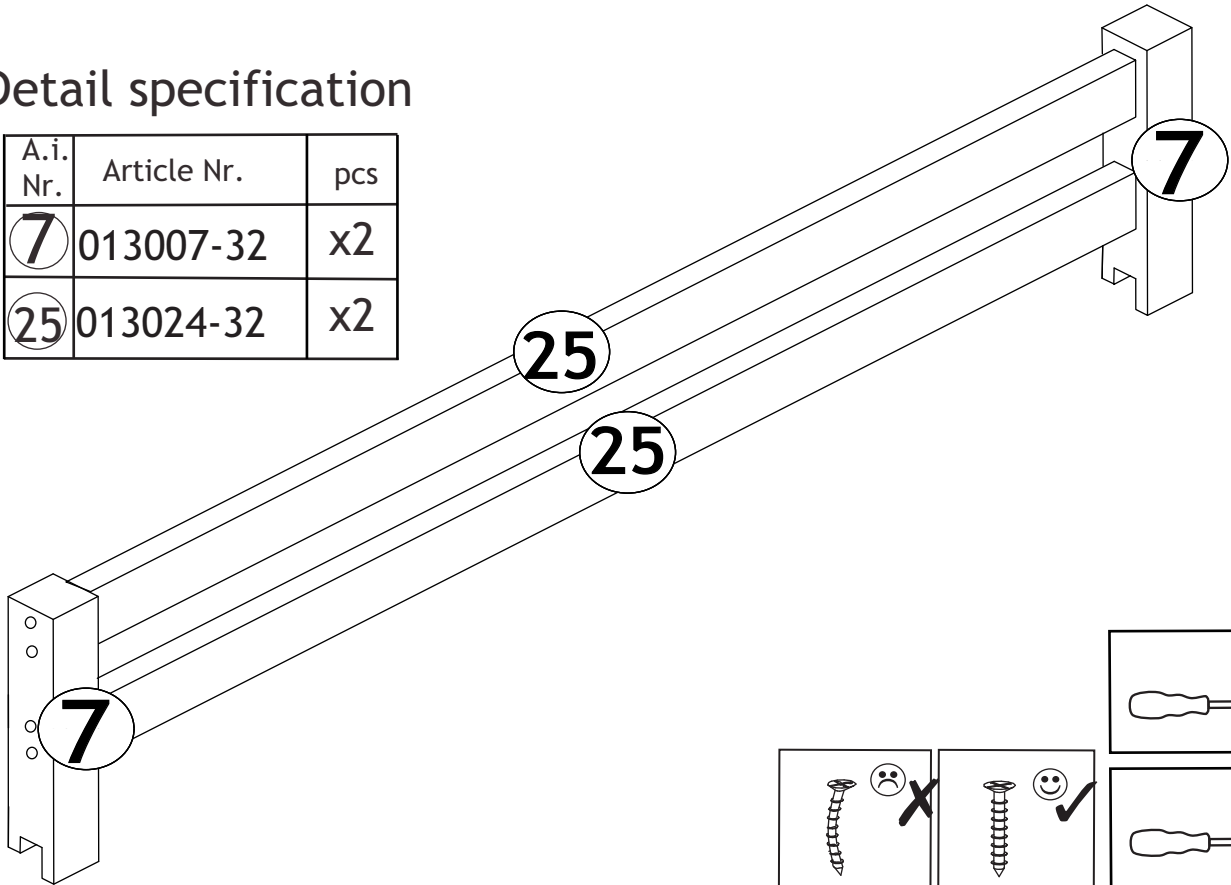

DE Überprüfungliste für Zubehör; UK Fittings checklist; FR Accessoir esliste de vérification. DK Checkliste for beslag;

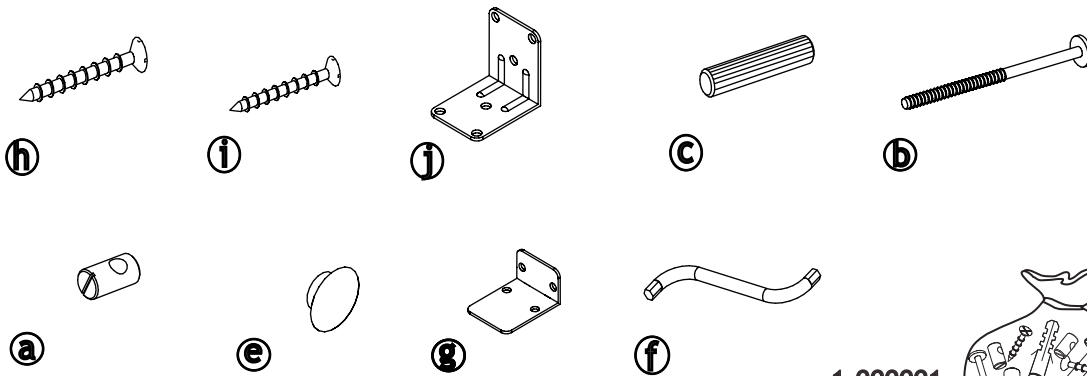

Fitting specification

A.i. Nr.	Article Nr.	Dimintions	pcs
h	1-000020-07	3,5x25	x6
i	1-000019-07	3,5x15	x8
j	1-000018-07	48x40x2,5	x2
c	1-000013-00	8x40	x4
b	1-000010-07	M6x100	x4
a	1-000011-07	M6x10/6	x4
e	1-000014-57	6x8	x4
g	1-000017-07	45x45x2	x2
f	1-000015-07	Z4	x1

1-000001=

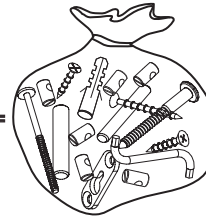

Hier können Sie die Schrauben zur besseren Identifizierung nachmessen.

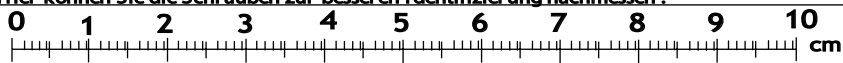

Artikel - Nr :;
 Type :;
 Farb/color/farue/colorer :;
 Kundennummer:;
 Name:;
 Strasse/str/vej: No:;
 PLZ: Ort/city/by/ville:

Tel. no :;
 Grund/reason/motif:

No	PART	QTY

37-0013+37-0001
37-0013+37-0005

1.

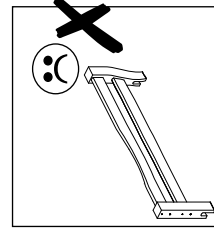
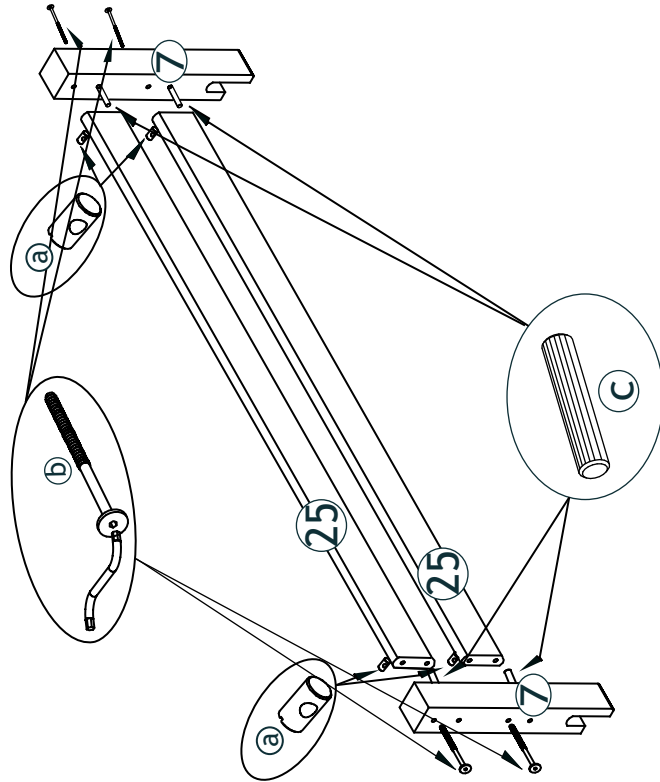

Close free holes with caps

Luk alle huller med propper

Schliessen Sie die offenen Löcher mit den Deckkappen

Fermez les trous découverts avec les chapes

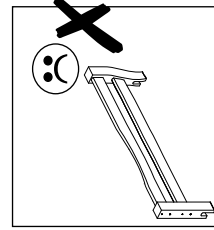

(UK)- Be aware of the risk of open fire and other heating sources close to the product

(DK)- Vær opmærksom på risikoen for åben ild og andre varmekilder i nærheden af produktet

(DE)- Beachtensichungen Sie die Gefahr des geöffneten Feuers und andere Wärmequellen nah an dem Produkt

(FR)- Ne pas placer le produit à proximité du feu ou de chauffage puissants

2.1.

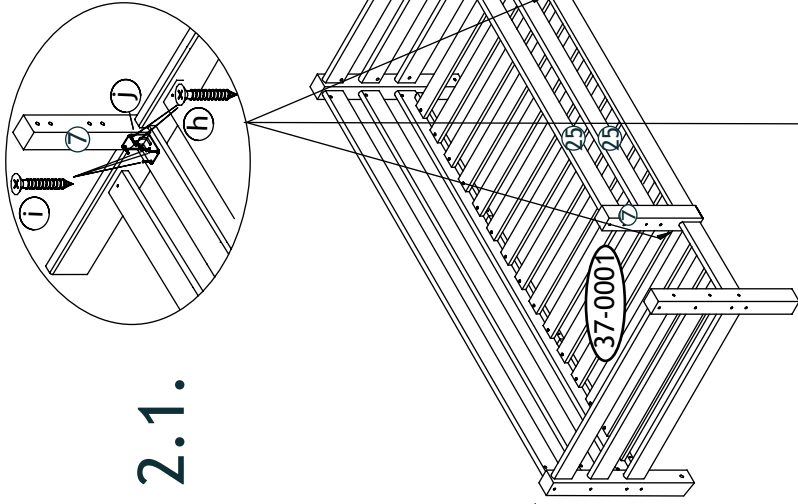

2.2.

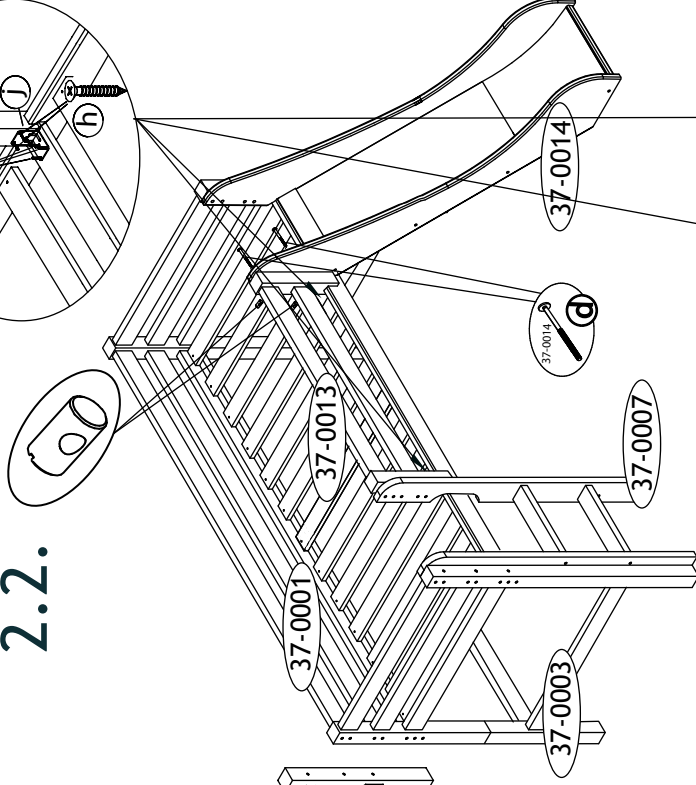

2.3.

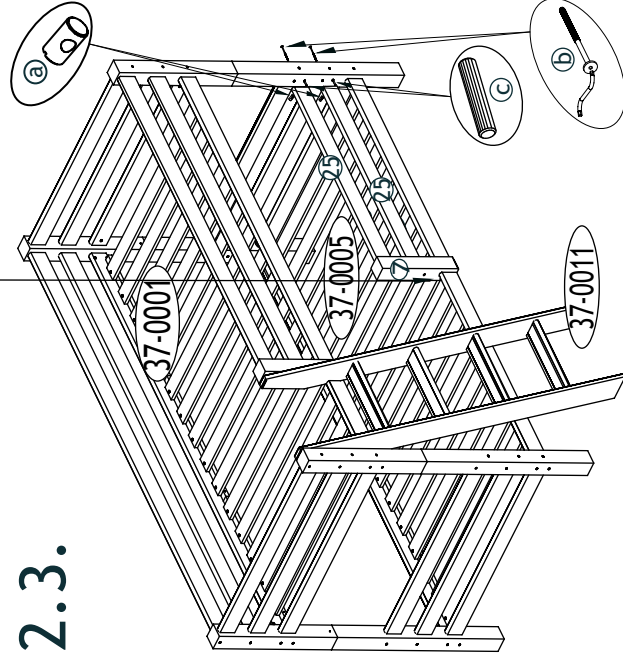

2.4.

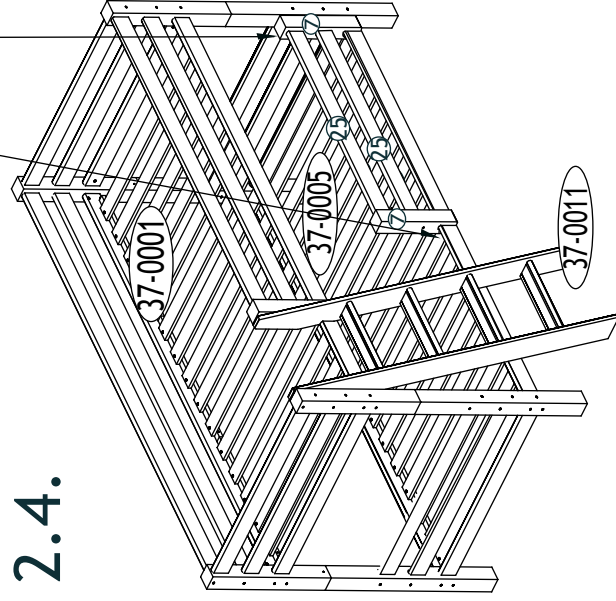

37-0013+37-0017

37-0013+37-0018

1.

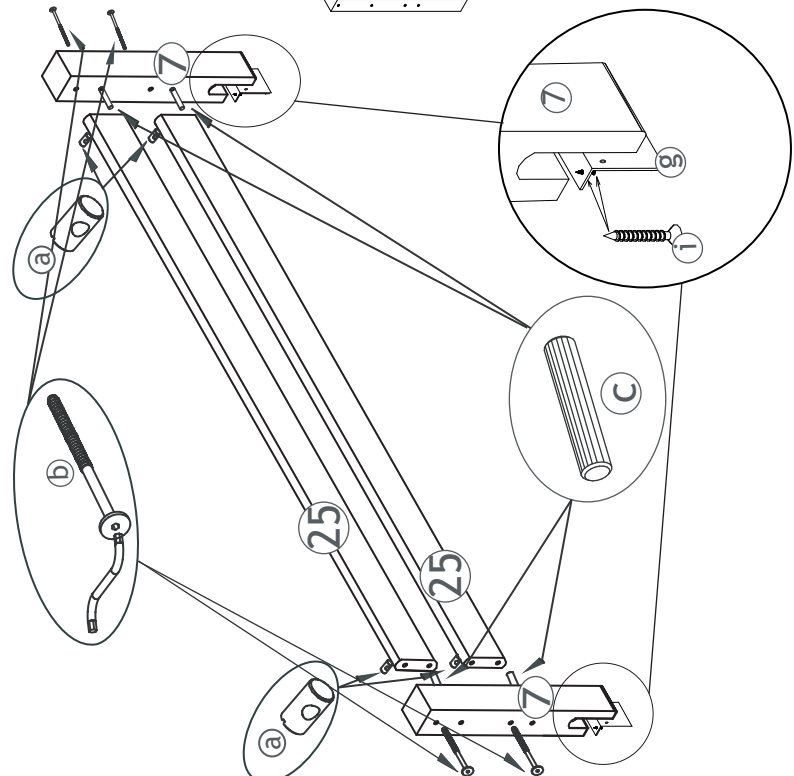

2.1.

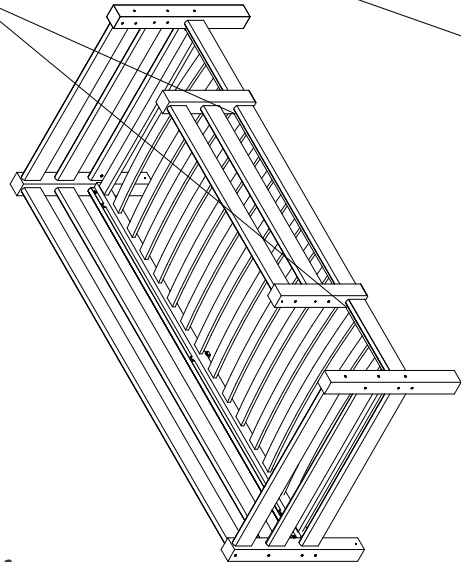

2.2.

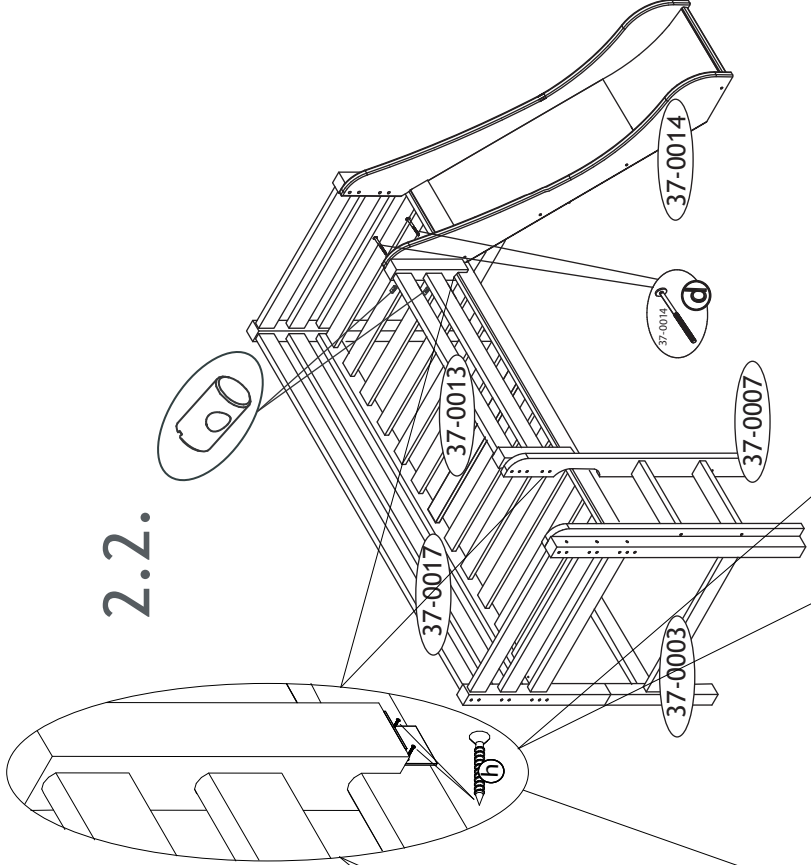

2.3.

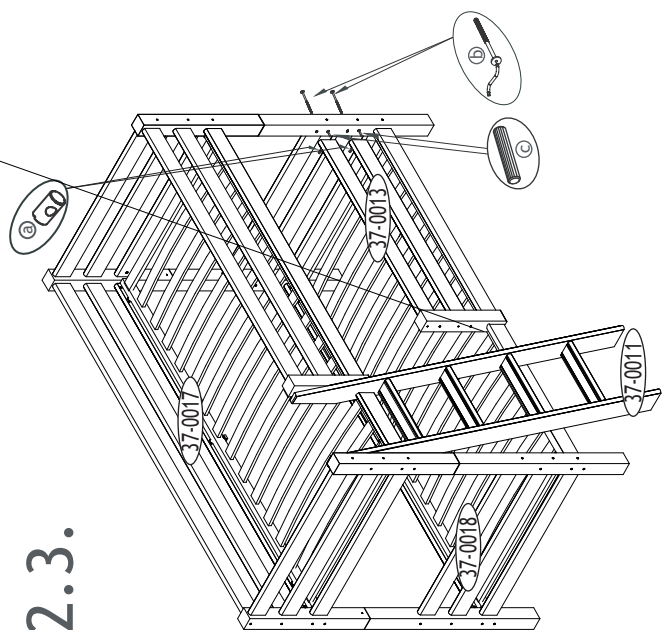

2.4.

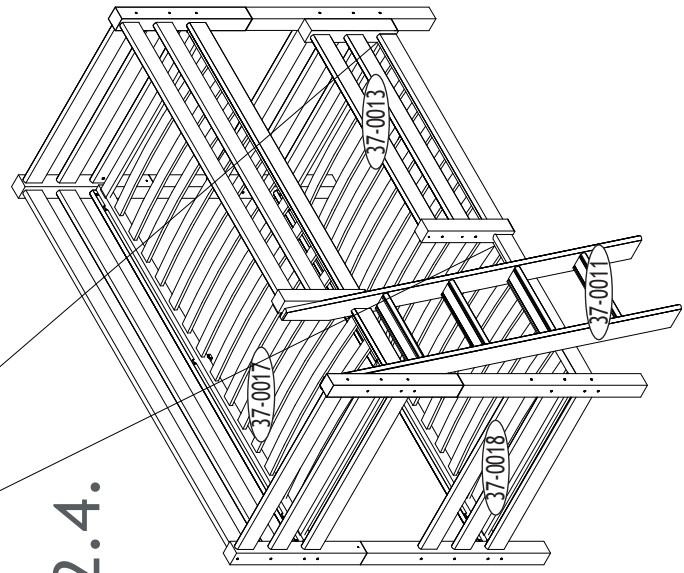

Close free holes with caps
 Luk alle huller med propper
 Schliessen Sie die offenen Löcher mit den Deckkappen
 Fermez les trous découverts avec les chapes

UK-Be aware of the risk of open fire and other heating sources close to the product
DK-Vær opmærksom på risikoen for åben ild og andre varmekilder i nærheden af produktet
DE-Berücksichtigen Sie die Gefahr des geöffneten Feuers und andere Wärmequellen nah an dem Produkt
FR-Ne pas placer le produit à proximité du feu ou de chauffages puissants

Ⓓ Aufbauanleitung

Ⓕ Notice de montage

Ⓖ Montagehandleiding

Ⓒ Montážní návod

Ⓗ Szerelési útmutató

Ⓓ Montaj talimatları

Ⓖ Assembly instruction

Ⓙ Istruzioni di montaggio

Ⓟ Instrukcja montażu

Ⓙ Navod na montaž

Ⓡ Instrucțiuni de montaj

Ⓡ Инструкция по монтажу

37-0038-32-000

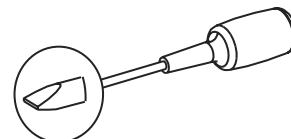
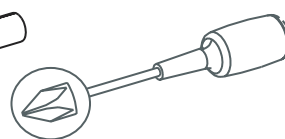
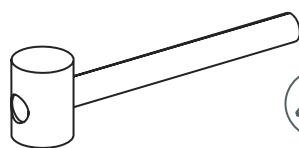
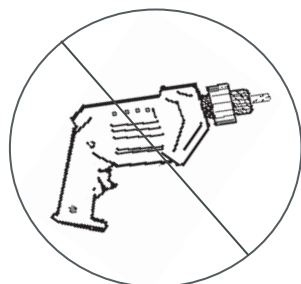
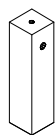
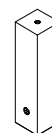

Service • Assistenza • Dienstverlening • Serwis Servis • Szerviz • Сервисная служба

Name • Nom • Nome • Naam • Nazwa • Jméno • Názov
Név • Denumire • Isim • Название

Nr. Nr. • No. • N° • Č • Sz • Номер

Typ • Тип • Type • Tip • Tipus • Druh • Тиро • Тип

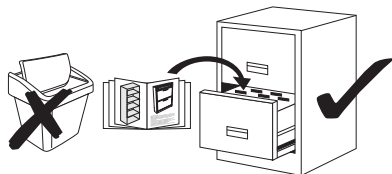
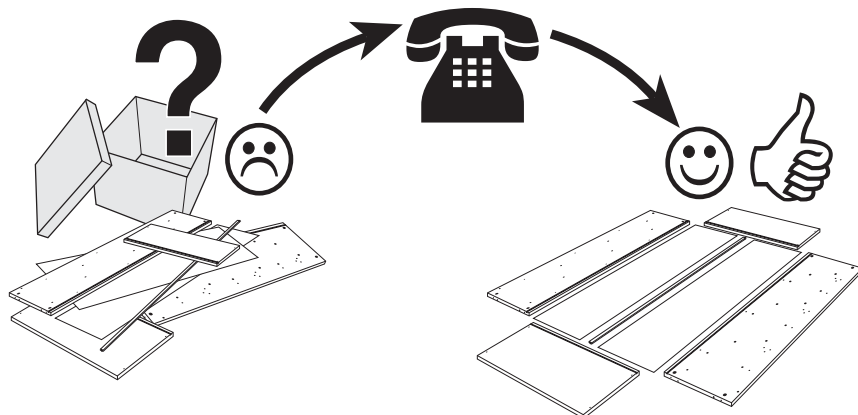

16	013108-32	x2
17	013109-32	x2

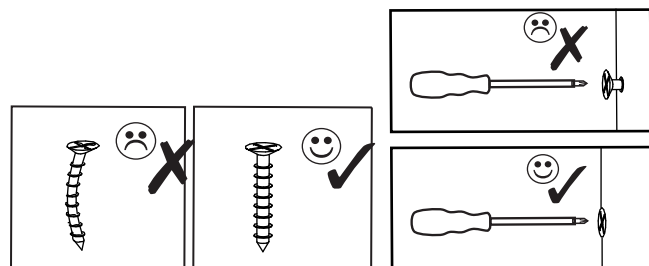

f



l



m

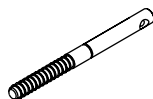

n



k



g



p



h

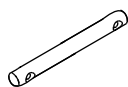

o

Fitting specification

A.i. Nr.	Article Nr.	Dimensions	pcs
f	1-000015-07	Z4	x1
l	1-000021-07	M10x15/28	x8
m	1-000022-07	M10x15/28	x4
n	1-000023-07	M10x115	x4
k	1-000024-07	M10x12	x8
g	1-000016-57	16x10	x8
o	1-000166-07	10x18	x4
p	1-000041-07	M6x55	x4
h	1-000027-07	8x15	x4

1-000001=

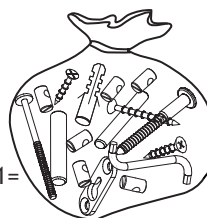

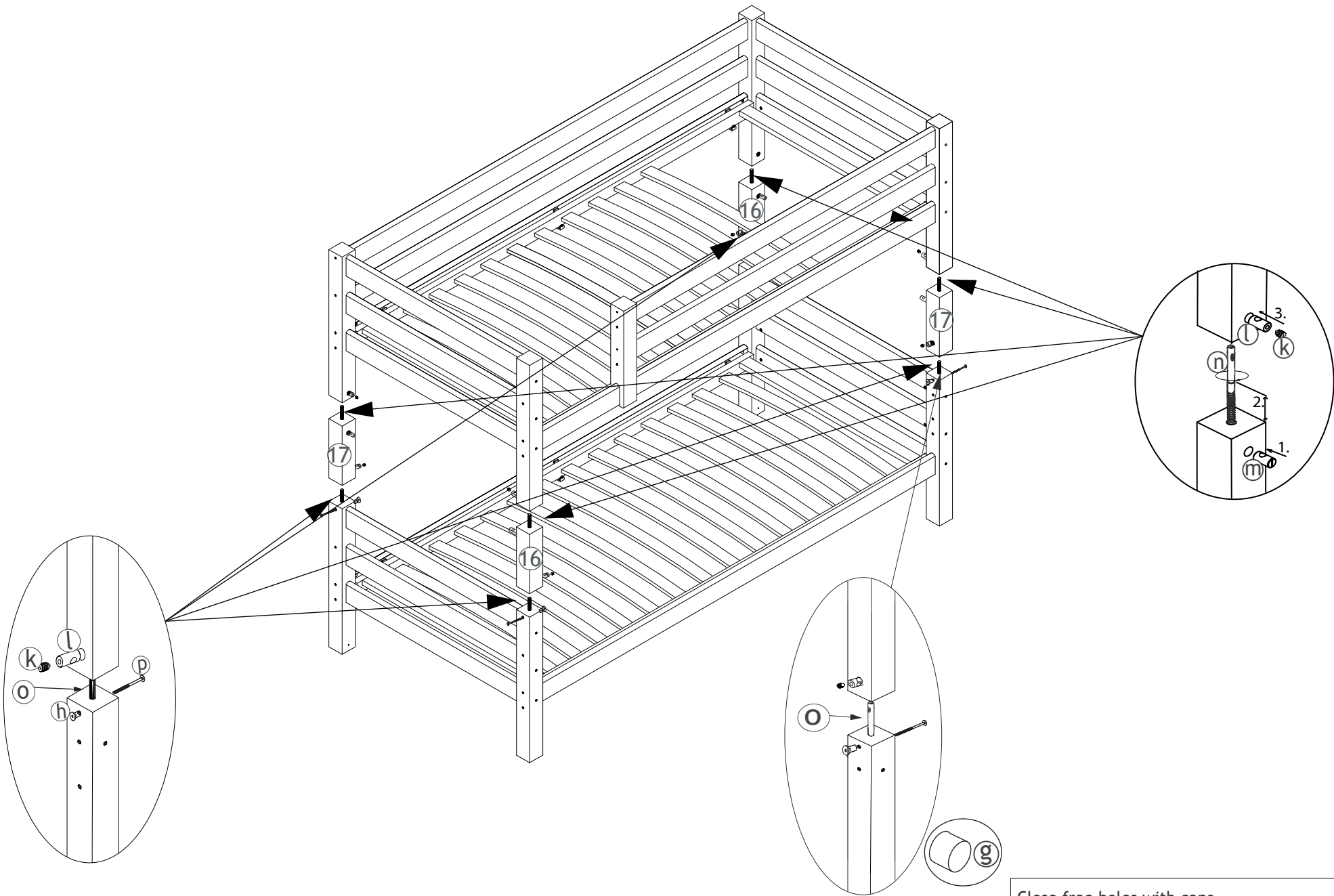

Close free holes with caps
 Luk alle huller med propper
 Schliessen Sie die offenen Löcher mit den Deckkappen
 Fermez les trous découverts avec les chapes

Ⓛ Aufbauanleitung

Ⓛ Notice de montage

Ⓛ Montagehandleiding

Ⓛ Montážní návod

Ⓛ Szerelési útmutató

Ⓛ Montaj talimatları

Ⓛ Assembly instruction

Ⓛ Istruzione di montaggio

Ⓛ Instrukcja montażu

Ⓛ Navod na montaž

Ⓛ Instrucțiuni de montaj

Ⓛ Инструкция по монтажу

37-0011-32-000

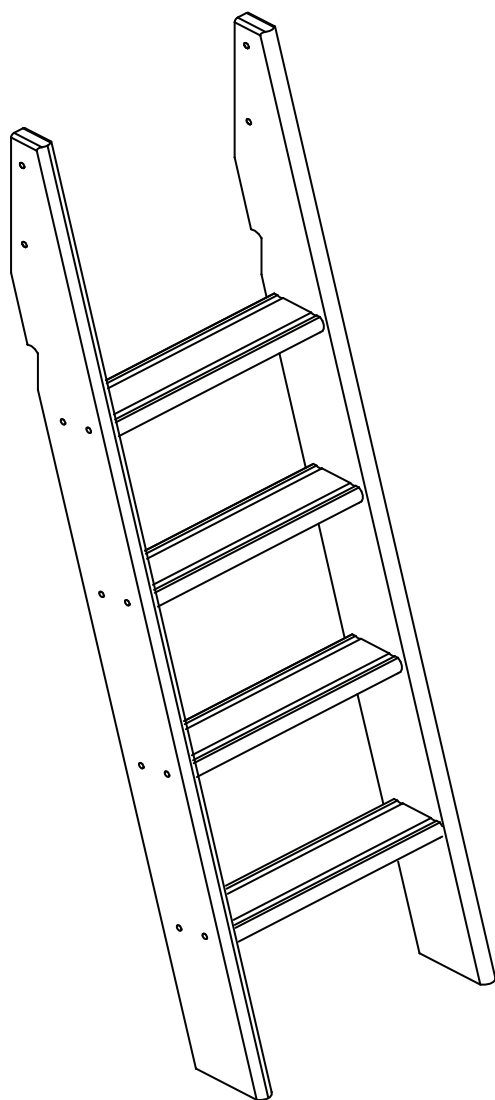

Product fulfil the standard "DIN EN 747-1:2015,DIN EN 747-2:2015"
Produktet opfylder krav til standard "DIN EN 747-1:2015,DIN EN 747-2:2015"
Produkt entspricht der Norm "DIN EN 747-1:2015,DIN EN 747-2:2015"
Produit conforme au standard "DIN EN 747-1:2015,DIN EN 747-2:2015"

IMPORTANT-READ CAREFULLY AND RETAIN
WICHTIG-SORGFÄLTIG LESEN UND AUFBEWAHREN
VIGTIGT-LÆS grundigt igennem og opbevar
IMPORTANT-LIRE ATTENTIVEMENT ET A CONSERVER

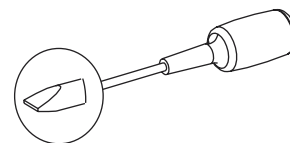
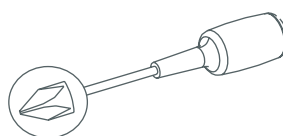
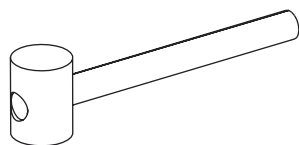
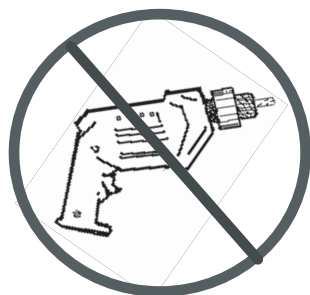

DIN EN 747-1:2015
DIN EN 747-2:2015

Service • Assistenza • Dienstverlening • Serwis Servis • Szerviz • Сервисная служба

Name • Nom • Nome • Naam • Nazwa • Иméно • Názov
Név • Denumire • Isim • Название

Nr. • No. • N° • Č • Sz • Номер

Typ • Type • Tip • Tipus • Druh • Тiро • Тип

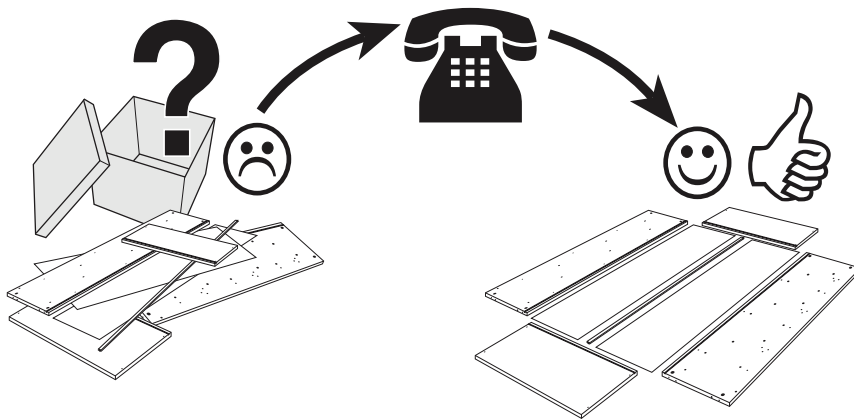
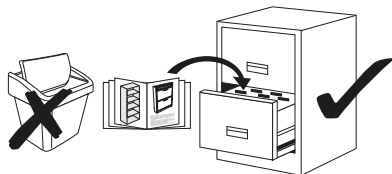

Detail specification

A.i. Nr.	Article Nr.	pcs
23	013022-32	x2
19	013018-32	x4

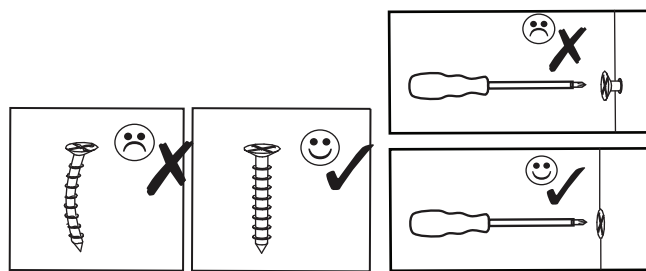
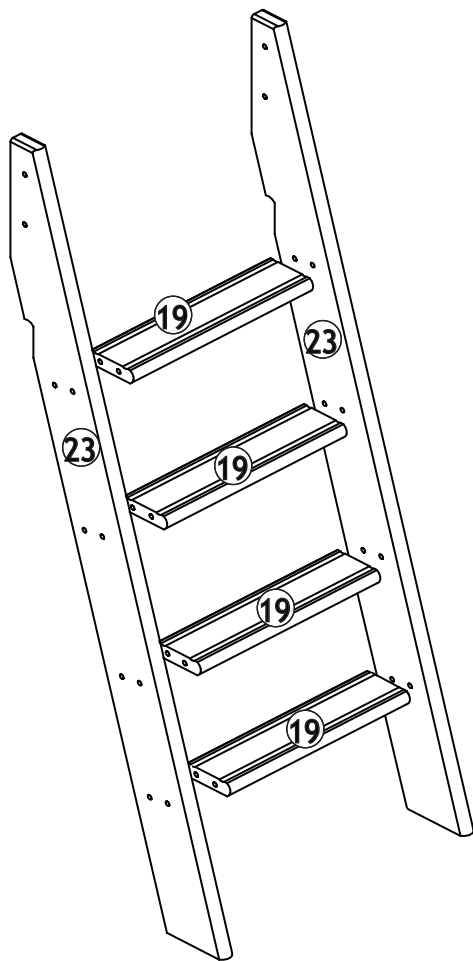

Fitting specification

A.i. Nr.	Article Nr.	Dimintions	pcs
o	1-000025-07	M6x85	x2
p	1-000026-07	M6x120	x2
t	1-000027-07	8x15	x2
e	1-000014-57	8x13	x4
r	1-000028-07	7x60	x16
s	1-000029-07	4x50	x2

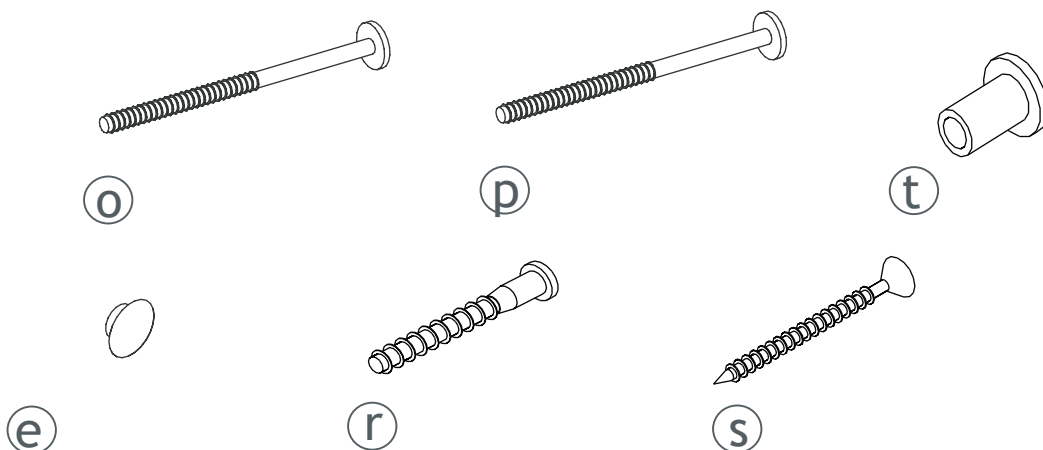

1-000001=

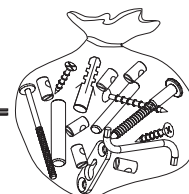

1.

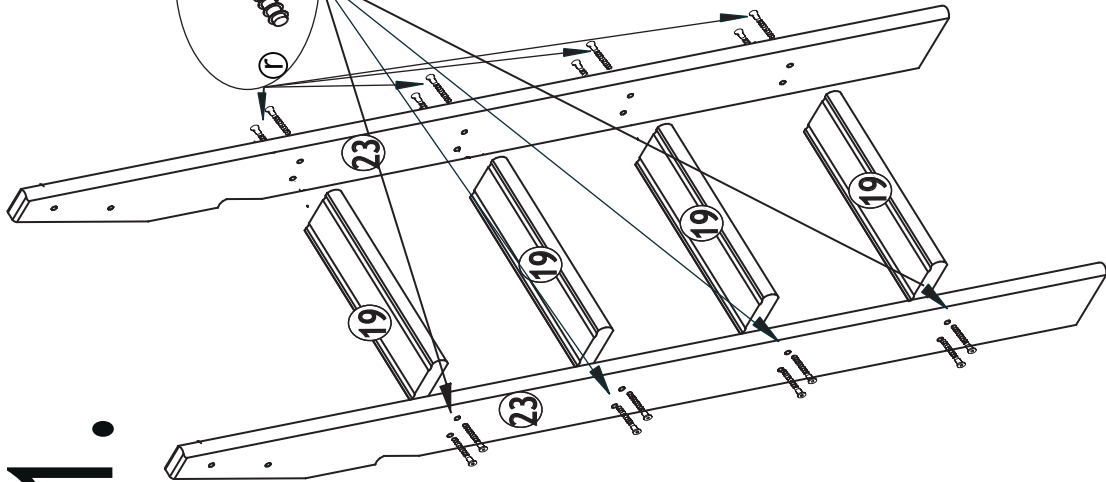

2.

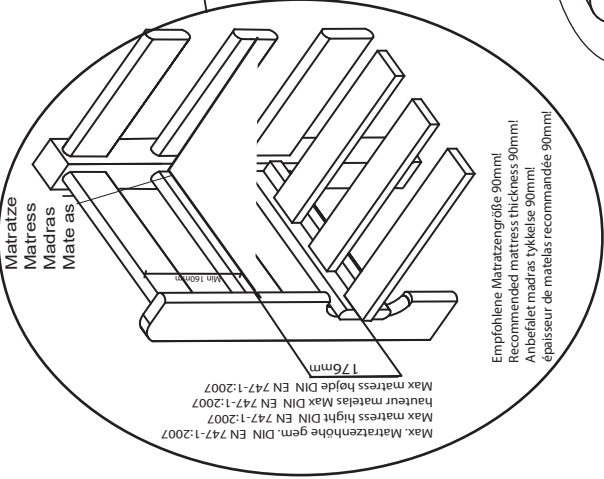
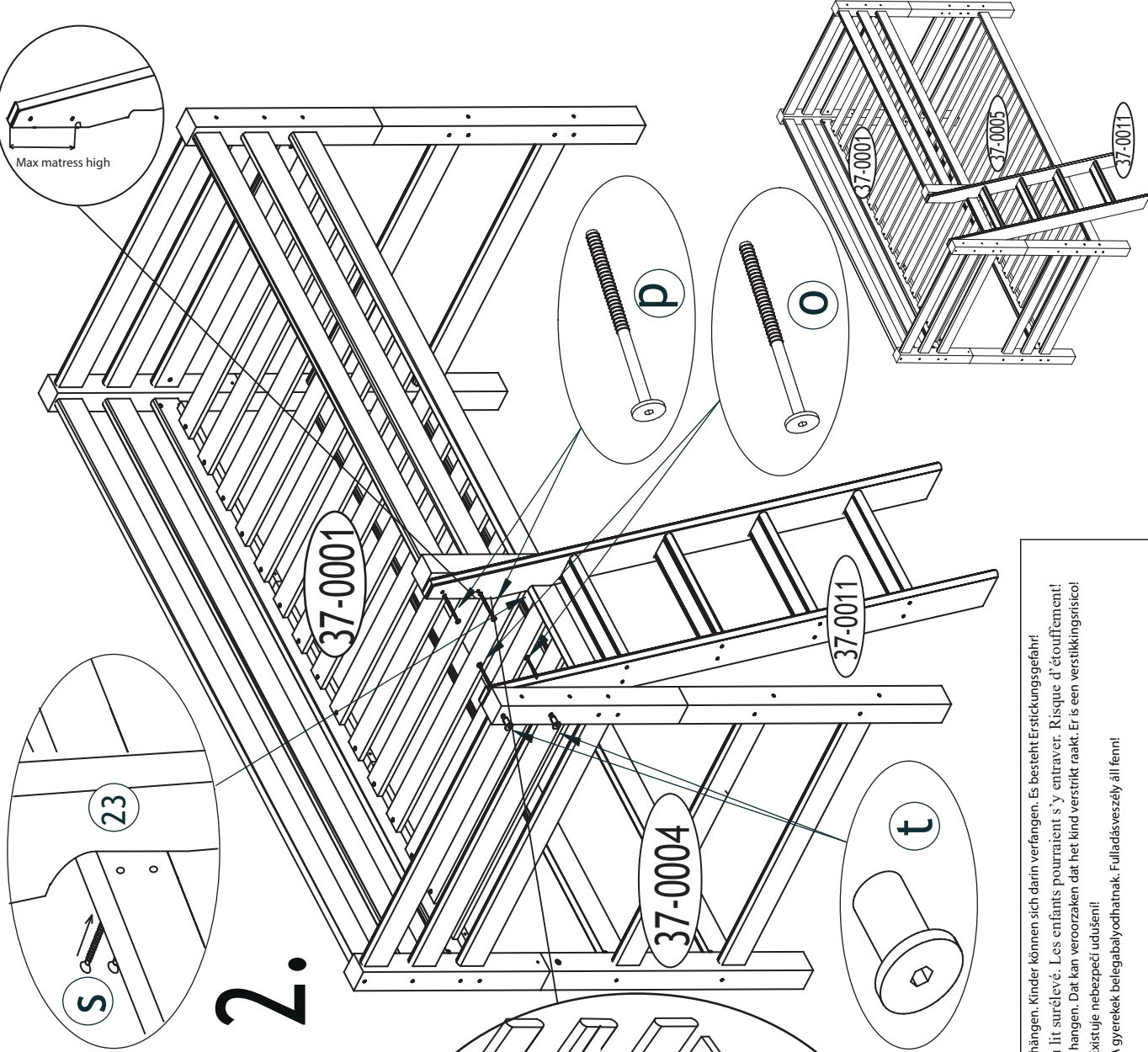

Maträtze
Matress
Madras
Mate as

Empfohlene Matratzengröße: 90mm!
 Recommended mattress thickness: 90mm!
 Aanbevolen matras dikte: 90mm!
 épaisseur de matelas recommandée: 90mm!

Max. Matratzenhöhe gem. DIN EN 747-1:2007
 hauteur matelas Max. DIN EN 747-1:2007
 Max. matress höjde DIN EN 747-1:2007
 170mm

- ⓘ **WARNUNG** - Es dürfen keine Stricke, Schnüre, Kordeln, Gurte oder Bänder an dem Hochbett befestigt werden bzw. vom Bett herunterhängen. Kinder können sich darin verfangen. Es besteht Erststückerungsgefahr!
- ⓘ **AVERTISSEMENT** - Aucune corde, ficelle, ceinture ni cordon ou ruban ne doit être attachés ou suspendus au lit surélévé. Les enfants pourraient s'y entramer. Risque d'étouffement!
- ⓘ **WAARSCHUWING** - Geen touwen, snaren, snoeren, riemen of linten mogen worden bevestigd aan het bed of van het hoge kinderbed hangen. Dat kan veroorzaken dat het kind verstrikt raakt. Er is een verstikkingsrisico!
- ⓘ **UPOZORNĚNÍ** - Z patrové postele nesmí viset žádná lana, provazy, šňůry, opasky či pásky. Děti by se do nich mohly zamotat a udusit. Existuje nebezpečí udusění!
- ⓘ **FIGYELM** - Nem szabad köteleket, zsinórokat, spárgákat vagy szalagokat a magas ágyhoz kötni, ill. ilyenek nem lógathatnak le onnan. A gyerekek belegabalyodhatnak. Fulladásveszély áll fenn!
- ⓘ **UAVARI** - Ranzaya herhangli bir ip, sicim, kordon, kemer veya şerit bağlanmamalı ve sarkıtılmamalıdır. Boğulma tehlikesi vardır.
- ⓘ **ATTENZIONE** - Al letto non devono essere attaccati o appesi funi, corde, cavi, cravatte, cordoncini (cravatte gibt es gar nicht) perché i bambini vi possono rimanere impigliati. Vi è il rischio di soffocamento!
- ⓘ **OSTRZEZENIE** - Nie mocować do łózka plecówego żadnych lin, sznurów, pasów ani taśm, które mogłyby z niego zwisać, bo dzieci mogą się w nie zaplątać. Rzyzko uduszenia się!
- ⓘ **UPOZORNENIE** - Laná, provazy, šňůry, opasky či pásky nemôžu byť pripravené alebo visieť dole z vysokej detskej postelky. Deti sa môžu zaplietať do usnenia!
- ⓘ **ATENȚIE!** Nu legați ori atarnați funii, snururi, corzi, curele ori panglici de patutul înalt al copilului. Copiii se pot încurca în ele. Există riscul de sufocare!
- ⓘ **Внимание!** Не привязывать к верхней кровати ленты, веревки, пояса и т.д. Ребенок может задушаться. Возможен риск удушья.

Close free holes with caps
 Luk alle huller med propper
 Schliessen Sie die offenen Löcher mit den Deckkappen
 Fermez les trous découverts avec les chapes



Ⓛ Das Bett muss dicht an der Wand stehen, d.h. es muss an einer Seite die Wand berühren. Wenn dies nicht möglich ist, darf der Abstand zwischen Bett und Wand nicht mehr als 75 mm betragen oder er muss größer als 230 mm sein, damit das Kind nicht zwischen Bett und Wand hängen bleibt, falls es herunterfällt. Das Bett darf nicht verwendet werden, wenn ein Teil fehlt oder beschädigt ist. Alle Schrauben und Verbindungsteile müssen stabil sein. Stellen Sie sicher, dass keine Schrauben lose sind oder fehlen.

Hergestellt von: Hoppekids SIA / Novadnieki / LV-3801 / Saldus / www.hoppekids.com DIN EN 747-1+A1:2015

Ⓛ Le lit doit être placé tout près du mur, voire collé au mur. Si cela n'est pas possible, prévoir une distance de 75 mm maximum entre le lit et le mur, ou bien supérieure à 230 mm, pour éviter que l'enfant ne puisse rester coincé entre le lit et le mur en cas de chute. Si une partie du lit est manquante ou endommagée, le lit ne doit plus être utilisé. Toutes les vis et les fixations doivent toujours être bien serrées. Vérifiez qu'aucune vis n'est desserrée ou manquante.

Fabriqué par: Hoppekids SIA / Novadnieki / LV-3801 / Saldus / www.hoppekids.com DIN EN 747-1+A1:2015

Ⓛ Het bed moet in de buurt van de muur te staan, dat wil zeggen de ene kant moet de muur raken, indien het niet mogelijk is, moet de afstand tussen het bed en de muur niet groter dan 75mm zijn of het moet groter zijn dan 230mm zijn, zodat het kind moet het vallen, niet kon raken tussen het bed en de wall. Should not be used if any structural part is broken or missing. Every screw and connection must always be steady. Make sure that there are no loose or missing screws!

Vervaardigd door: Hoppekids SIA / Novadnieki / LV-3801 / Saldus / www.hoppekids.com DIN EN 747-1+A1:2015

Ⓛ Postel musí stát u zdi, tedy jedna strana se musí dotýkat stěny; pokud to ale není možné, vzdálenost mezi postelí a zdi nesmí být větší než 75 mm, nebo musí být větší než 230 mm, aby dítě, kdyby vypadlo, nemohlo zůstat viset mezi postelí a stěnou. Nepoužívejte, je-li nějaká část poškozená nebo chybí. Každý šroub a připojení musí být vždy stabilní. Ujistěte se, že žádné šrouby nejsou volné nebo chybí!

Výrobce: Hoppekids SIA / Novadnieki / LV-3801 / Saldus / www.hoppekids.com DIN EN 747-1+A1:2015

Ⓛ Az ágyat közvetlenül a fal mellé állítsa, úgy hogy az egyik oldalával érintkezzen a fallal. Ha ez nem lehetséges, akkor az ágy és a fal közötti távolság nem lehet nagyobb 75 mm-nél, vagy legyen nagyobb 230 mm-nél, hogy ha a gyermek kiesne, ne szoruljon be az ágy és a fal közé. Ne használja az ágyat, ha valamely szerkezeti eleme hibás vagy hiányzik. Minden csavar és csatlakozás legyen stabil. Bizonyosodjon meg arról, hogy nincsenek meglazult csavarok és, hogy egy csavar sem hiányzik.

Framleitt af: Hoppekids SIA / Novadnieki / LV-3801 / Saldus / www.hoppekids.com DIN EN 747-1+A1:2015

Ⓛ Yatak duvara yakın şekilde durmalıdır bundan dolayı bir taraflıya duvara temas etmeli. Bu mümkün değilse duvara olan mesafe 75 mm den fazla olmamalı veya 230 mm den fazla mesafe olmalıdır, düşmesi halinde çocuğun yatakla duvar arasında sıkışmaması için. Yatağın bir parçası eksik veya hasarlıysa kullanmayın Tüm civatalar ve bağlantı parçaları stabil olmalı. Civataların gevşek veya eksik olmadığından emin olun.

Tarafından üretilmiştir: Hoppekids SIA / Novadnieki / LV-3801 / Saldus / www.hoppekids.com DIN EN 747-1+A1:2015

Ⓛ The bed must stand against the wall, i.e. one side must touch the wall, if it is not possible, the distance between the bed and the wall must be less than 75mm or it must be greater than 230mm, so that if the child falls out, they could not get caught between the bed and the wall. Should not be used if any structural part is broken or missing. Every screw and connection must always be steady. Make sure that there are no loose or missing screws!

Made by: Hoppekids SIA / Novadnieki / LV-3801 / Saldus / www.hoppekids.com DIN EN 747-1+A1:2015

Ⓛ Il letto deve stare attaccato muro, cioè un lato deve toccare il muro. Se ciò non fosse possibile, la distanza tra il letto e la parete non deve essere maggiore di 75 mm o deve essere superiore a 230 mm, in modo che, se dovesse cadere, il bambino non rimanga impigliato tra il letto e il muro. Non deve essere utilizzato se un suo pezzo dovesse mancare o essere danneggiato. Tutte le viti e i raccordi devono essere stabili. Assicurarsi che non vi siano viti staccate o mancanti.

Prodotto da: Hoppekids SIA / Novadnieki / LV-3801 / Saldus / www.hoppekids.com DIN EN 747-1+A1:2015

Ⓛ Łóżko musi stać bezpośrednio przy ścianie, czyli z jednej strony dotykać ściany. Jeśli nie jest to możliwe, odległość między łóżkiem a ścianą musi być mniejsza niż 75 mm albo większa niż 230 mm, tak aby dziecko w razie wypadnięcia nie zakleszczyło się między łóżkiem a ścianą. Nie używać łóżka, jeśli brakuje jakiejś części lub jest ona uszkodzona. Wszystkie śruby i połączenia muszą być zawsze stabilne. Upewnić się, że nie ma żadnych luźnych lub brakujących śrub!

Wyprodukowane przez: Hoppekids SIA / Novadnieki / LV-3801 / Saldus / www.hoppekids.com DIN EN 747-1+A1:2015

Ⓛ Postel' musí stát' v blízkosti steny, t. j. na jednej strane sa musí dotýkať steny. Ak to nie je možné, nesmie byť vzdialenosť medzi postel'ou a stenou väčšia ako 75 mm alebo musí byť väčšia ako 230 mm, aby sa dieťa v prípade vypadnutia z posteľe nezachytilo medzi postel'ou a stenou. Postel' nie je možné používať, ak chýba určitý diel alebo je poškodený. Všetky skrutky a spojenia musia byť stabilné. Uistite sa, že nechýbajú žiadne skrutky alebo nie sú uvoľnené

Výrobca: Hoppekids SIA / Novadnieki / LV-3801 / Saldus / www.hoppekids.com DIN EN 747-1+A1:2015

Ⓛ Pat trebuie să stea lângă perete, adică de o parte trebuie să atingă perete, dacă este posibil, distanța dintre pat și peretele nu trebuie să fie mai mare de 75 mm sau trebuie să fie mai mare de 230 mm, astfel încât copilul, ar trebui să cadă, nu ar putea fi prins între pat și peretele. Nu trebuie utilizat în cazul în care orice parte structurală este ruptă sau lipsă. Fiecare șurub și conexiune trebuie să fie întotdeauna constantă. Asigurați-vă că nu există nici un șurub și se lasă șuruburi!

Produs de: Hoppekids SIA / Novadnieki / LV-3801 / Saldus / www.hoppekids.com DIN EN 747-1+A1:2015

Ⓛ Кровать должна стоять у стены, т.е. одна сторона должна касаться стены, если это возможно, расстояние между кроватью и стеной должно быть не больше 75 мм или оно должно быть больше чем 230 мм, таким образом, чтобы, если он выпадет, не может попасть между кроватью и стеной. Не быть используется, если какой-либо структурной части сломаны или отсутствуют. Каждый винт и связи должны быть всегда стабильный. Убедитесь, что есть нет свободных и оставить винты!

Изготовитель: Hoppekids SIA / Novadnieki / LV-3801 / Saldus / www.hoppekids.com DIN EN 747-1+A1:2015