

Ⓛ Aufbauanleitung

Ⓛ Notice de montage

Ⓛ Montagehandleiding

Ⓛ Montážní návod

Ⓛ Szerelési útmutató

Ⓛ Montaj talimatları

Ⓛ Assembly instruction

Ⓛ Istruzione di montaggio

Ⓛ Instrukcja montażu

Ⓛ Navod na montaž

Ⓛ Instrucțiuni de montaj

Ⓛ Инструкция по монтажу

# 37-0017-32-09A

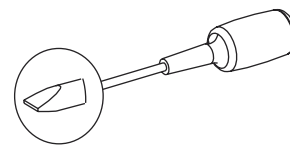
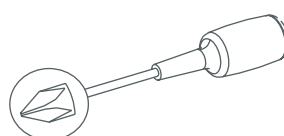
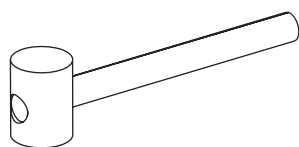
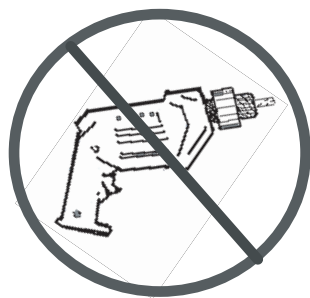
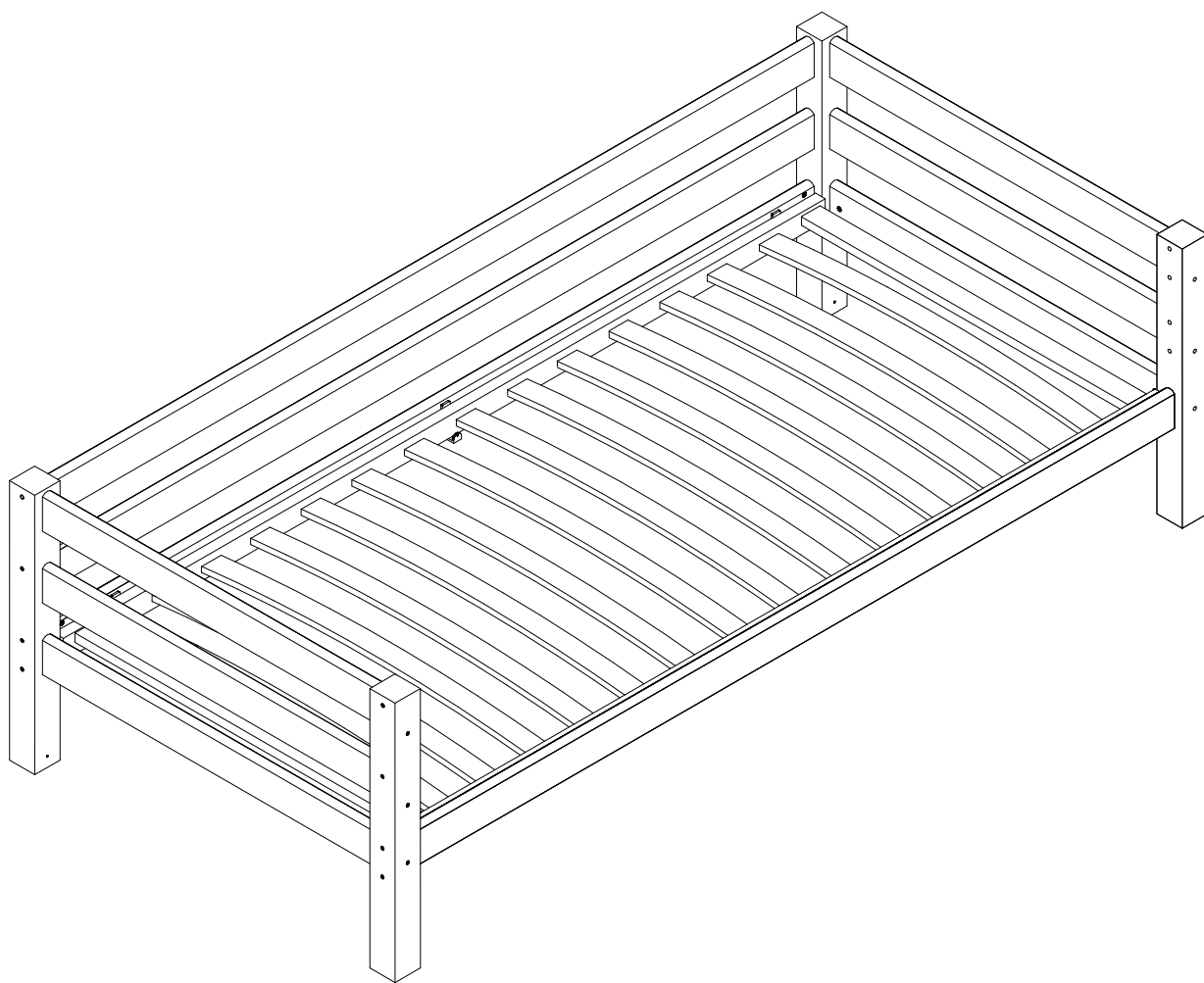

Product fulfill the standard "DIN EN 747-1:2015,DIN EN 747-2:2015"  
Produktet opfylder krav til standard "DIN EN 747-1:2015,DIN EN 747-2:2015"  
Produkt entspricht der Norm "DIN EN 747-1:2015,DIN EN 747-2:2015"  
Produit conforme au standard "DIN EN 747-1:2015,DIN EN 747-2:2015"

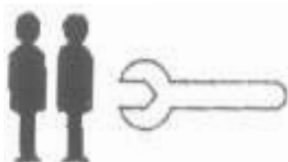

**DIN EN 747-1+A1:2015**  
**DIN EN 747-2+A1:2015**

**IMPORTANT-READ CAREFULLY AND RETAIN**  
**WICHTIG-SORGFÄLTIG LESEN UND AUFBEWAHREN**  
**VIGTIGT-LÆS grundigt igennem og opbevar**  
**IMPORTANT-LIRE ATTENTIVEMENT ET A CONSERVER**

# Service • Assistenza • Dienstverlening • Serwis Servis • Szerviz • Сервисная служба

Name • Nom • Nome • Naam • Nazwa • Jméno • Názov  
Név • Denumire • Isim • Название

Nr. • No. • N° • Č • Sz • Номер

Typ • Type • Tip • Tipus • Druh • Тіро • Тип

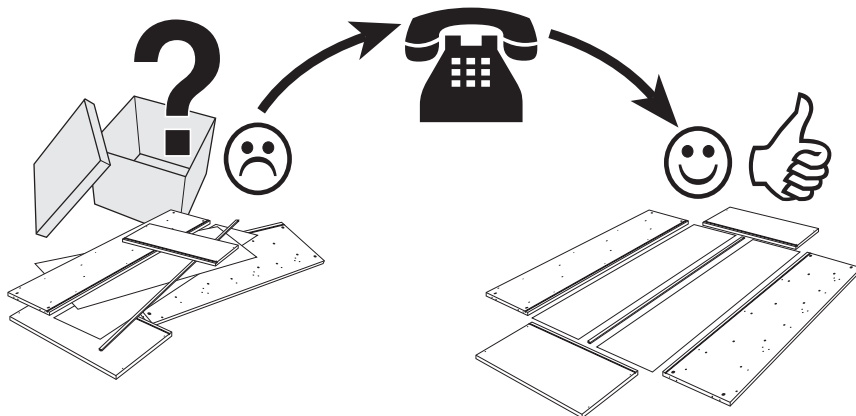

## Detail specification

A.i. Nr.	Article Nr.	pcs
①	013001-32	x2
②	013002-32	x2
④	013004-32	x2
⑤	013005-32	x2
⑥	013006-32	x4
⑤2	013058-32	x2
⑤3	999991-00	x1

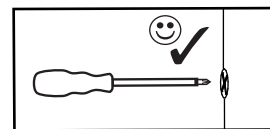
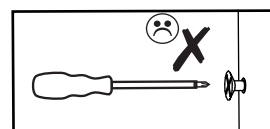
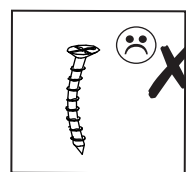
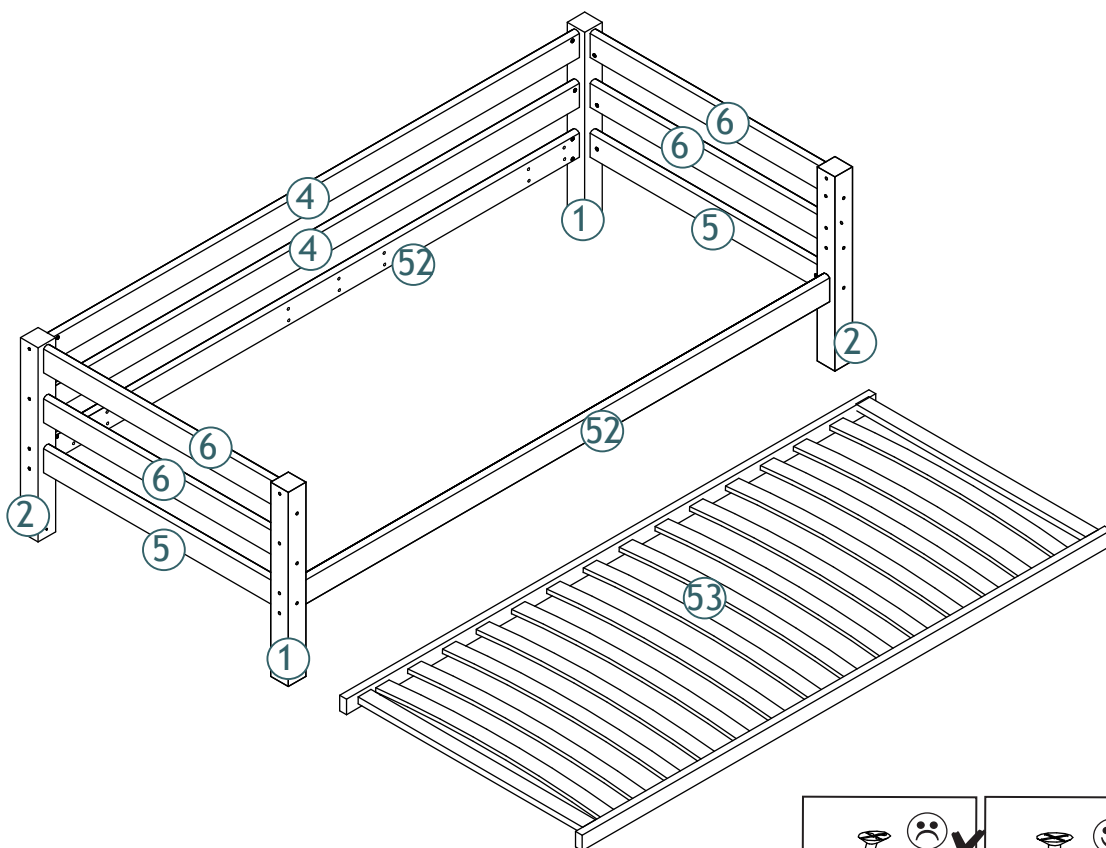

## Fitting specification

A.i. Nr.	Article Nr.	Dimensions	pcs
a	1-000011-07	10x18	x24
b	1-000010-07	M6x100	x24
c	1-000013-00	8x40	x24
d	1-000155-07	4x20	x12
e	1-000014-57	6x8	x12
f	1-000015-07	Z4	x1
g	1-000016-57	16x10	x4
i	1-000034-07	70x33	x6
h	1-000035-07	3x16	x6

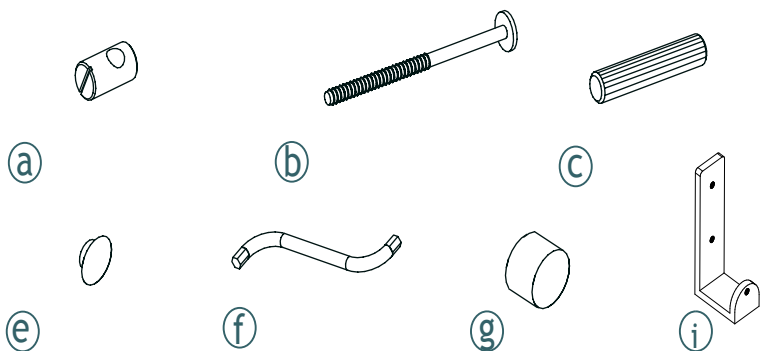

1-000001=

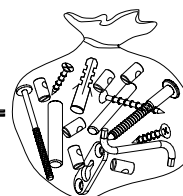

0  
10  
20  
30  
40  
50  
60  
70  
80  
90  
100  
110  
120  
130  
140  
150  
160  
170  
18

1.

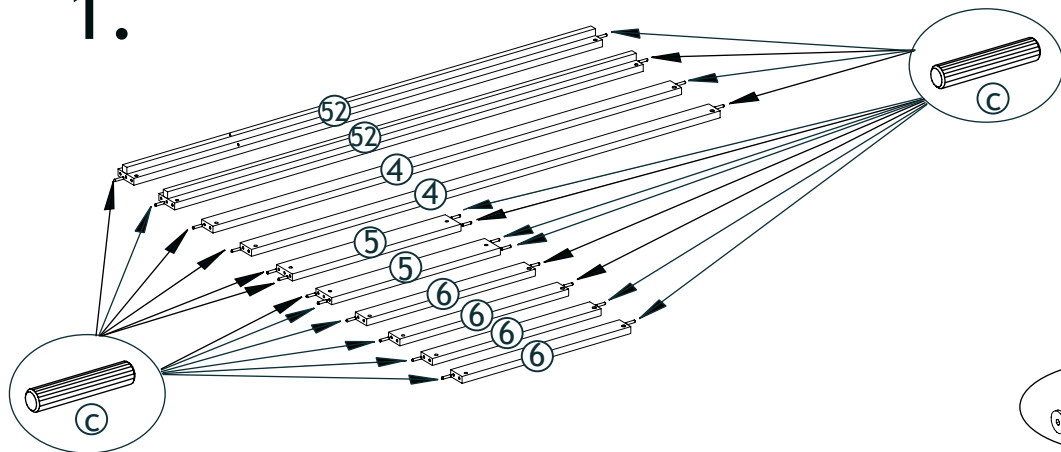

2.

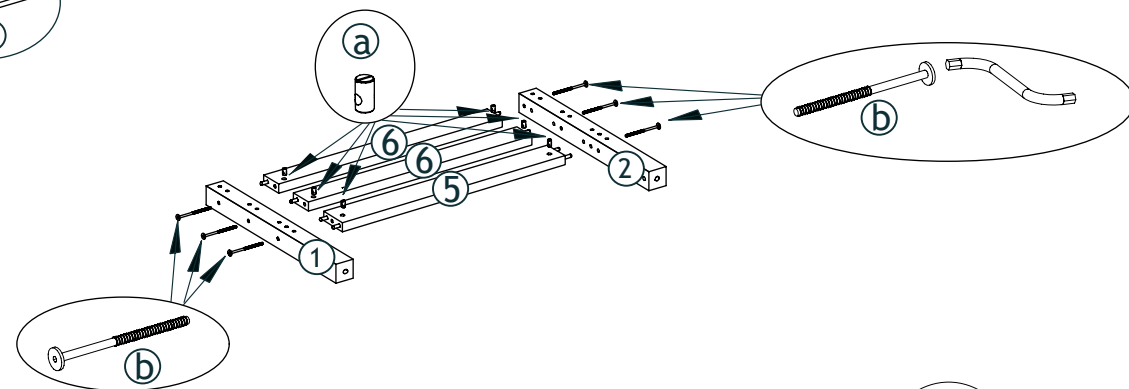

3.

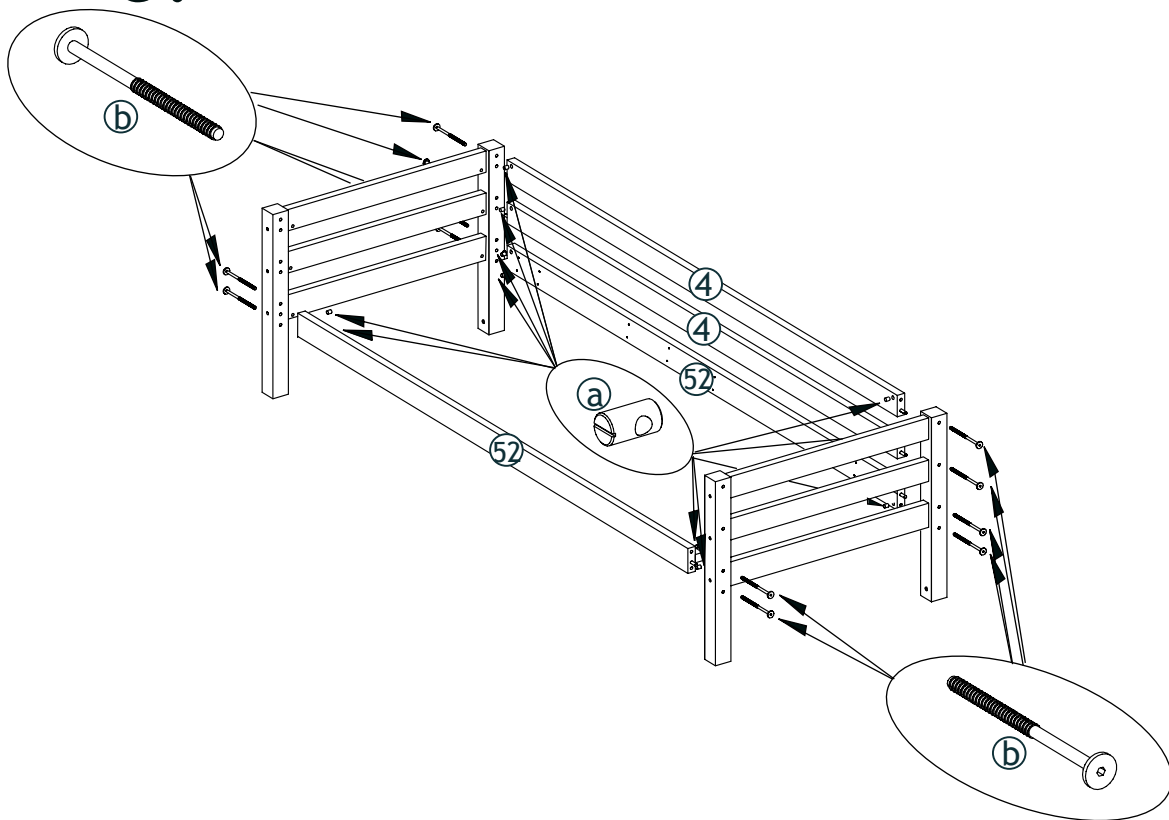

4.

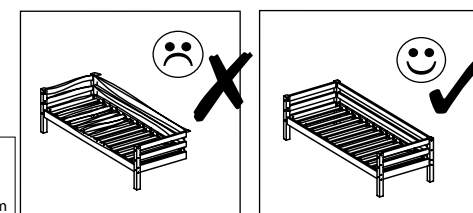
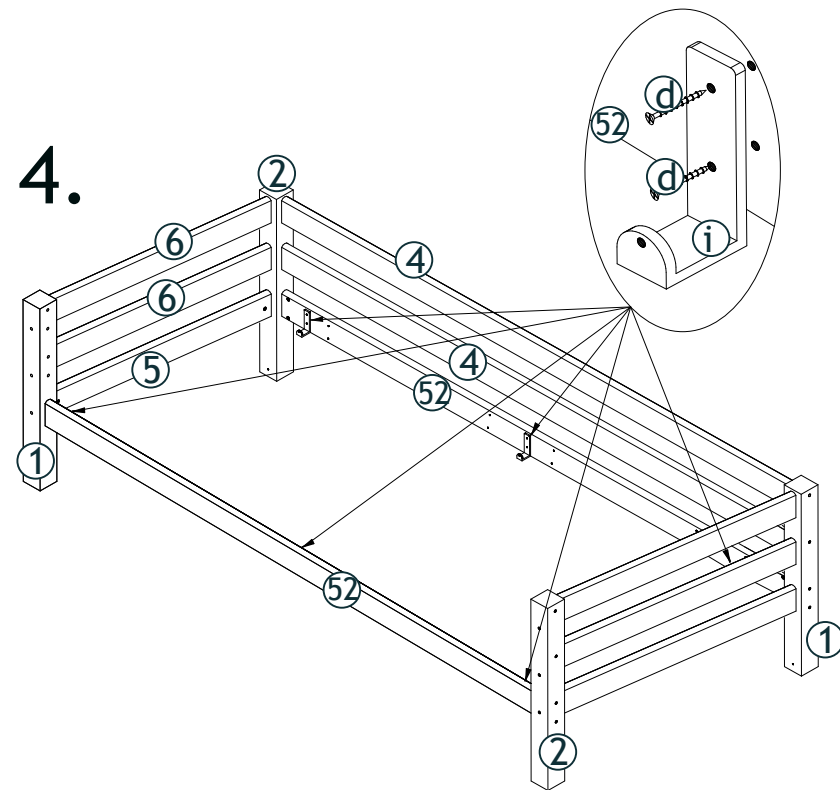

Empfohlene Matratzengröße 90mm!  
 Recommended mattress thickness 90mm!  
 Anbefalet madras tykkelse 90mm!  
 épaisseur de matelas recommandée 90mm

Ⓛ Aufbauanleitung

Ⓛ Notice de montage

Ⓛ Montagehandleiding

Ⓛ Montážní návod

Ⓛ Szerelési útmutató

Ⓛ Montaj talimatları

Ⓛ Assembly instruction

Ⓛ Istruzione di montaggio

Ⓛ Instrukcja montażu

Ⓛ Navod na montaž

Ⓛ Instrucțiuni de montaj

Ⓛ Инструкция по монтажу

# 37-0002-32-200

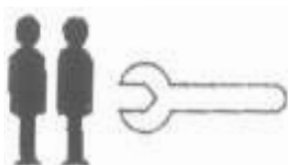
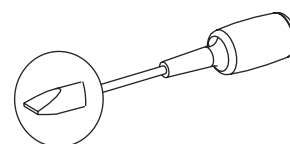
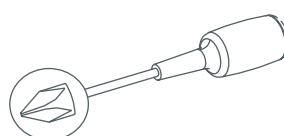
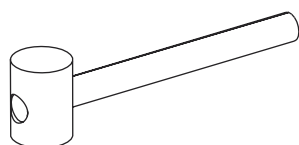
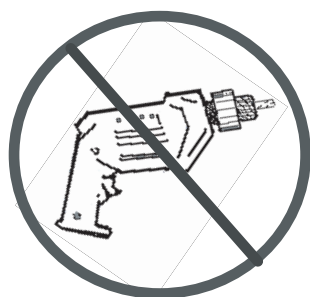
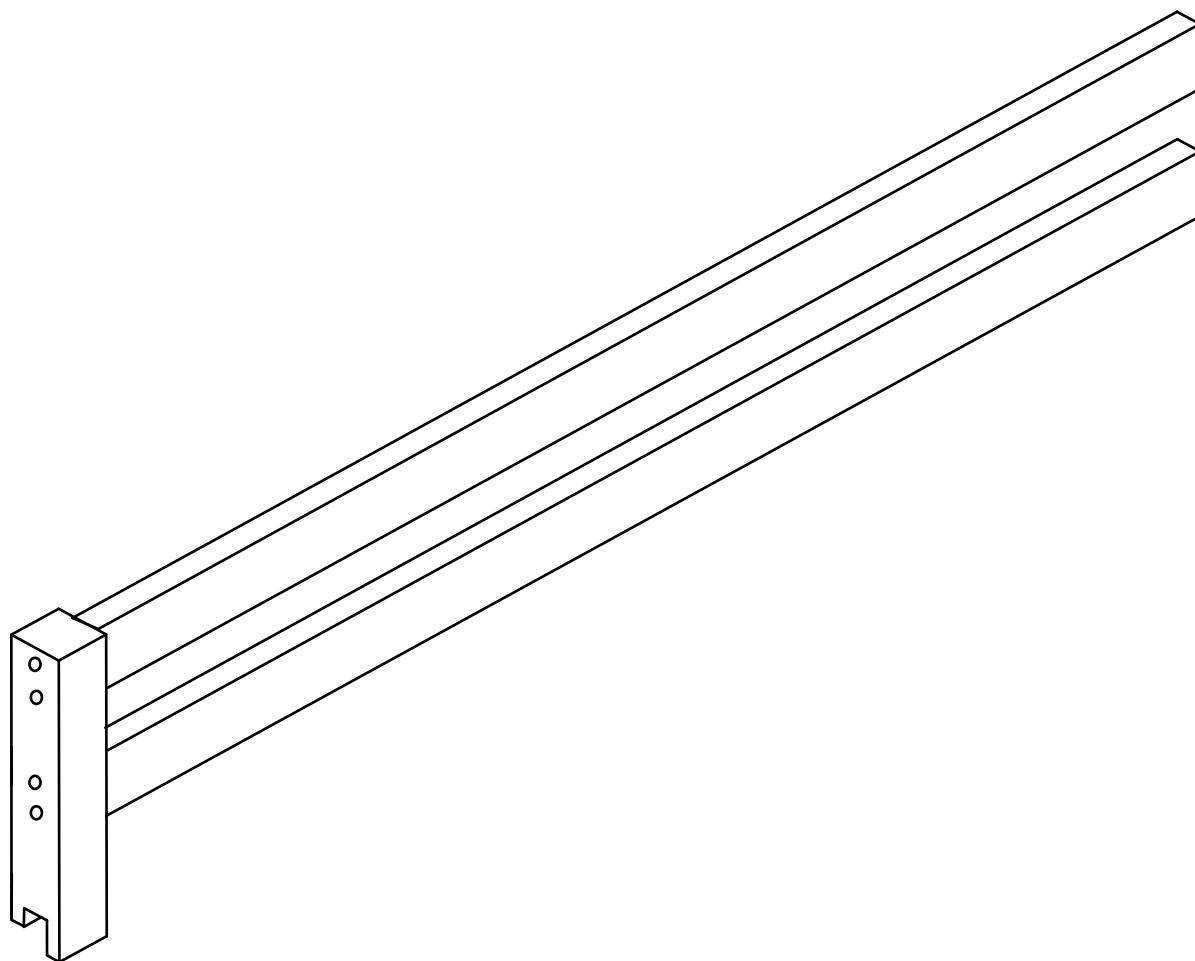

DIN EN 747-1+A1:2015  
DIN EN 747-2+A1:2015



# Service • Assistenza • Dienstverlening • Serwis Servis • Szerviz • Сервисная служба

Name • Nom • Nome • Naam • Nazwa • Jméno • Názov  
Név • Denumire • Isim • Название

Nr. • No. • N° • Č • Sz • Номер

Typ • Type • Tip • Tipus • Druh • Тип • Тип

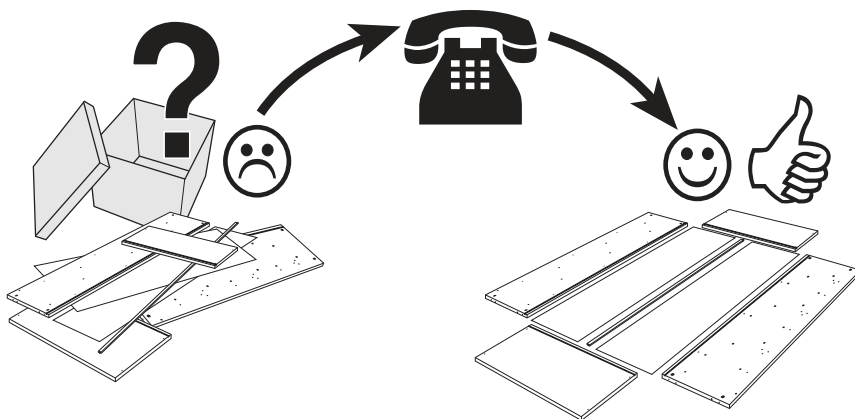

## Detail specification

A.i. Nr.	Article Nr.	pcs
7	013007-32	x1
8	013008-32	x2

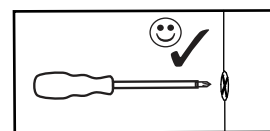
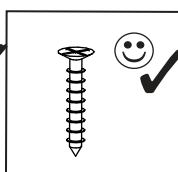
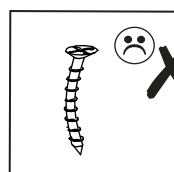

h



i



j



c



b



a



e



g



f

## Fitting specification

A.i. Nr.	Article Nr.	Dimensions	pcs
h	1-000020-07	3,5x25	x3
i	1-000019-07	3,5x15	x4
j	1-000018-07	48x40x2,5	x1
c	1-000013-00	8x40	x4
b	1-000010-07	M6x100	x4
a	1-000011-07	M6x10/6	x4
e	1-000014-57	6x8	x2
g	1-000017-07	45x45x2	x1
f	1-000015-07	Z4	x1

1-000001=



37-0001+37-0002

1.

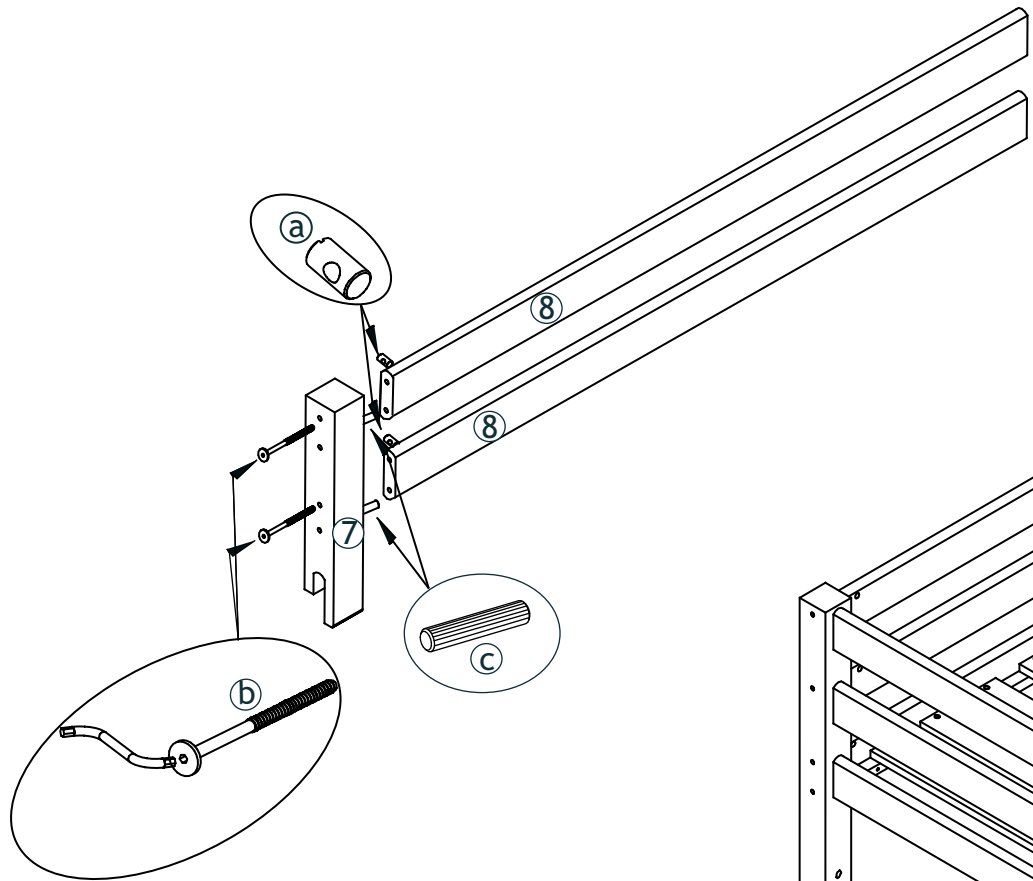

2.

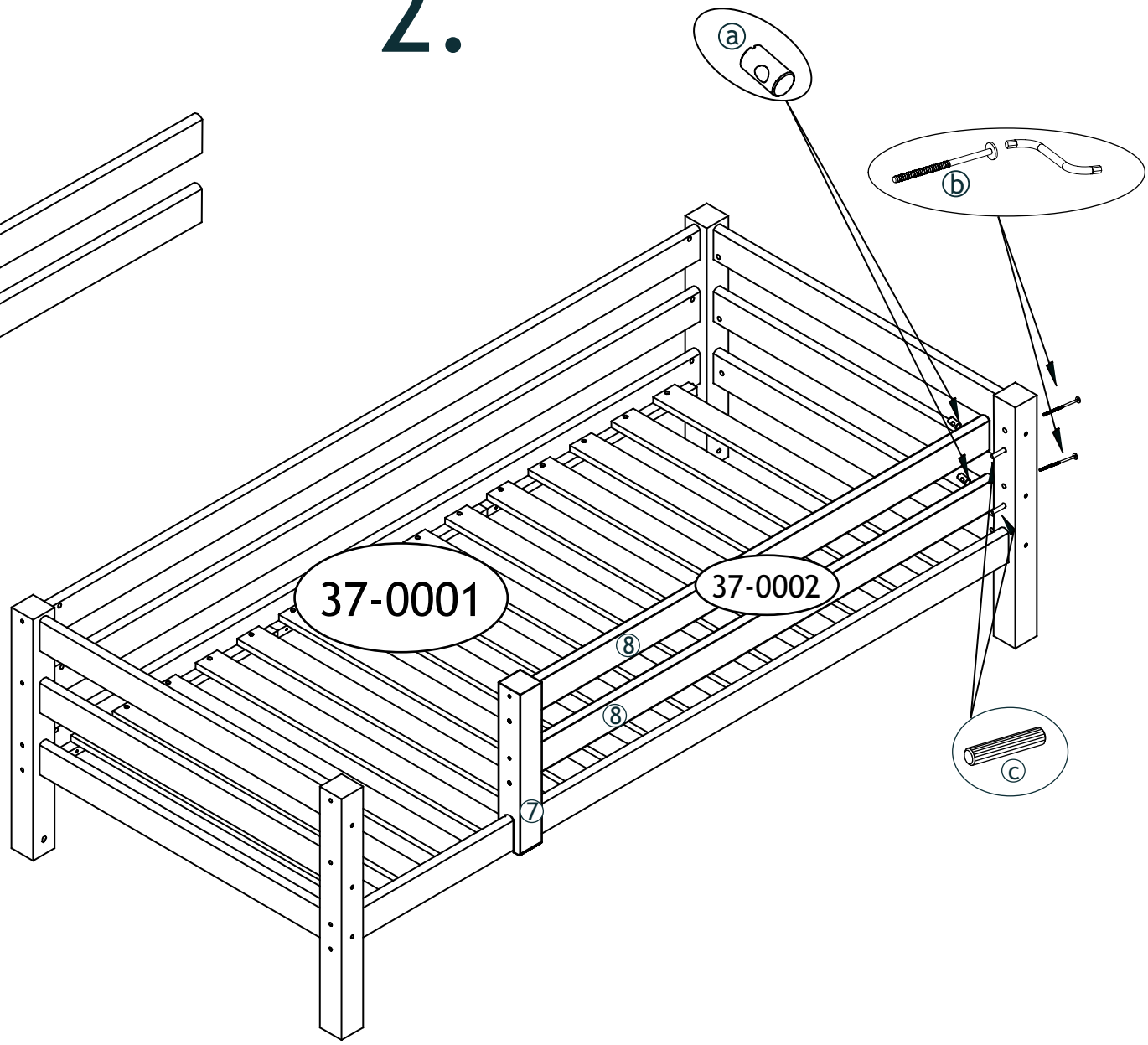



3.

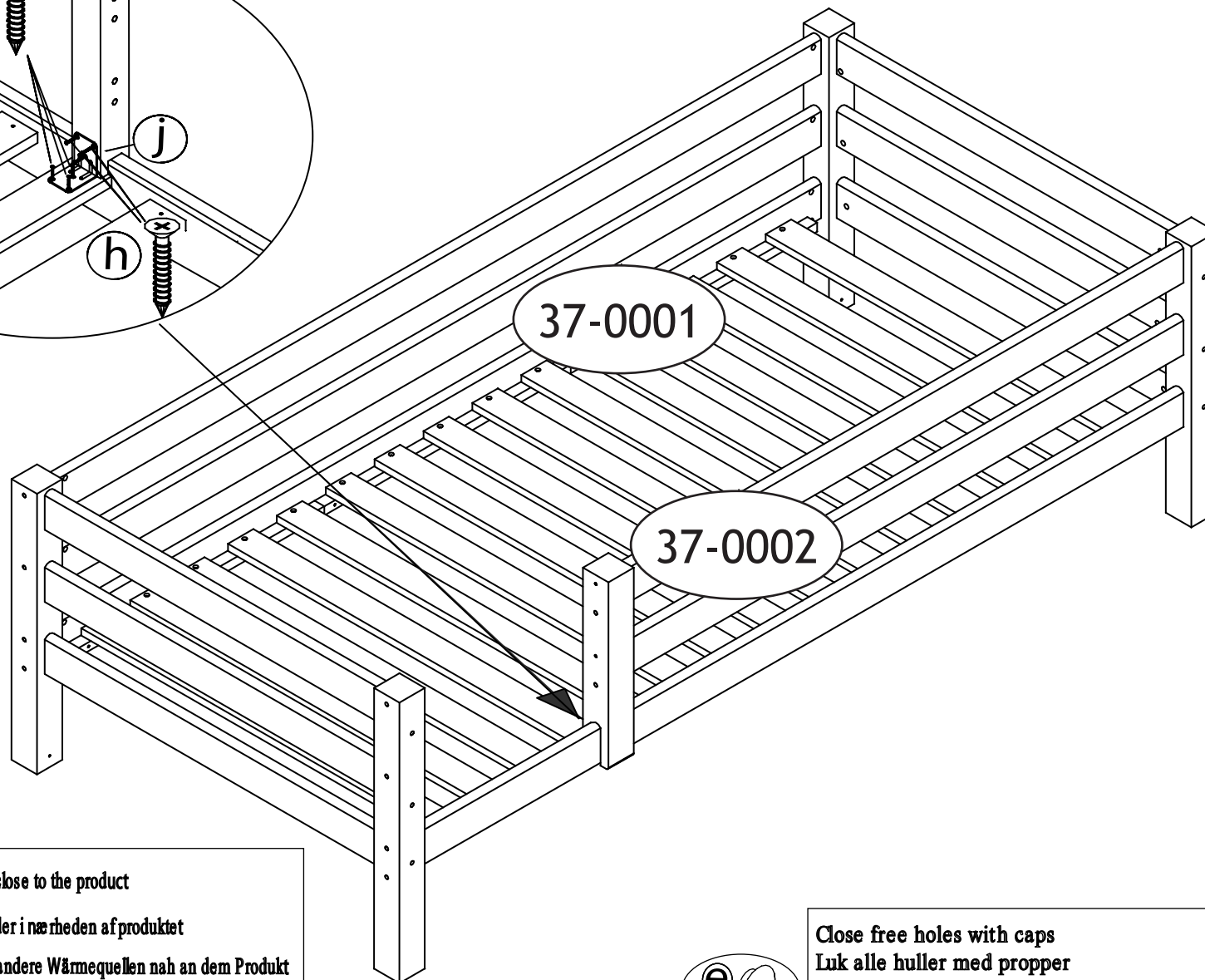
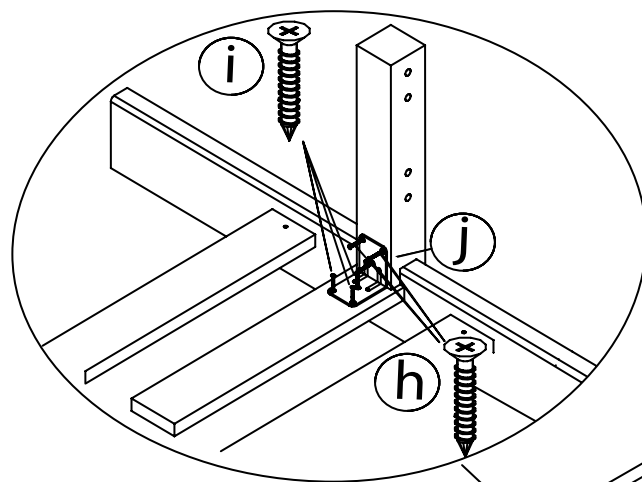

**UK** - Be aware of the risk of open fire and other heating sources close to the product

**DK** - Vær opmærksom på risikoen for åben ild og andre varmekilder i nærheden af produktet

**DE** - Berücksichtigen Sie die Gefahr des geöffneten Feuers und andere Wärmequellen nah an dem Produkt

**FR** - Ne pas placer le produit à proximité du feu ou du chauffage puissant



Close free holes with caps  
Luk alle huller med propper  
Schliessen Sie die offenen Löcher mit den Deckkappen  
Fermez les trous découverts avec les chapes

1.

2.

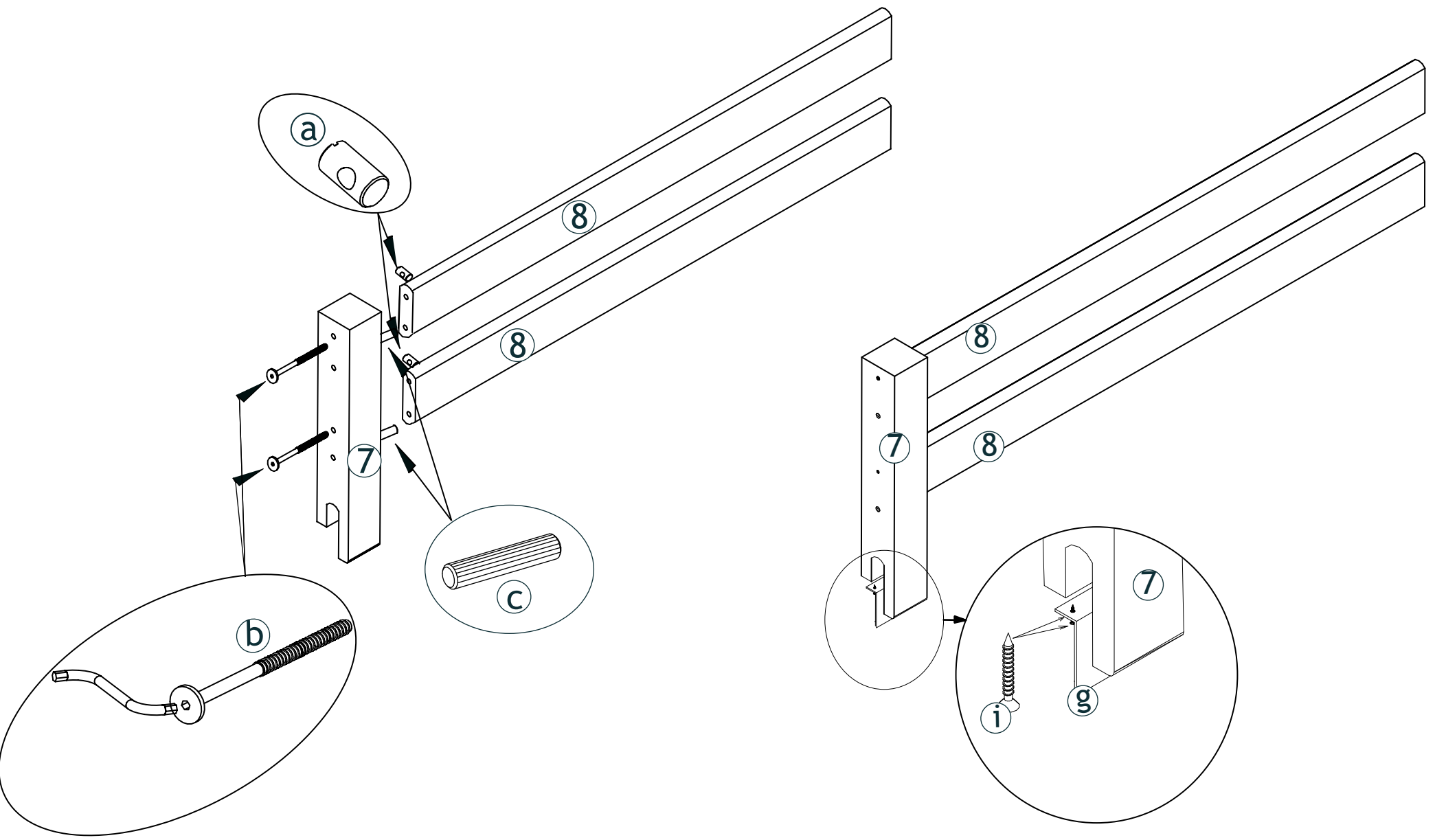



# 3.

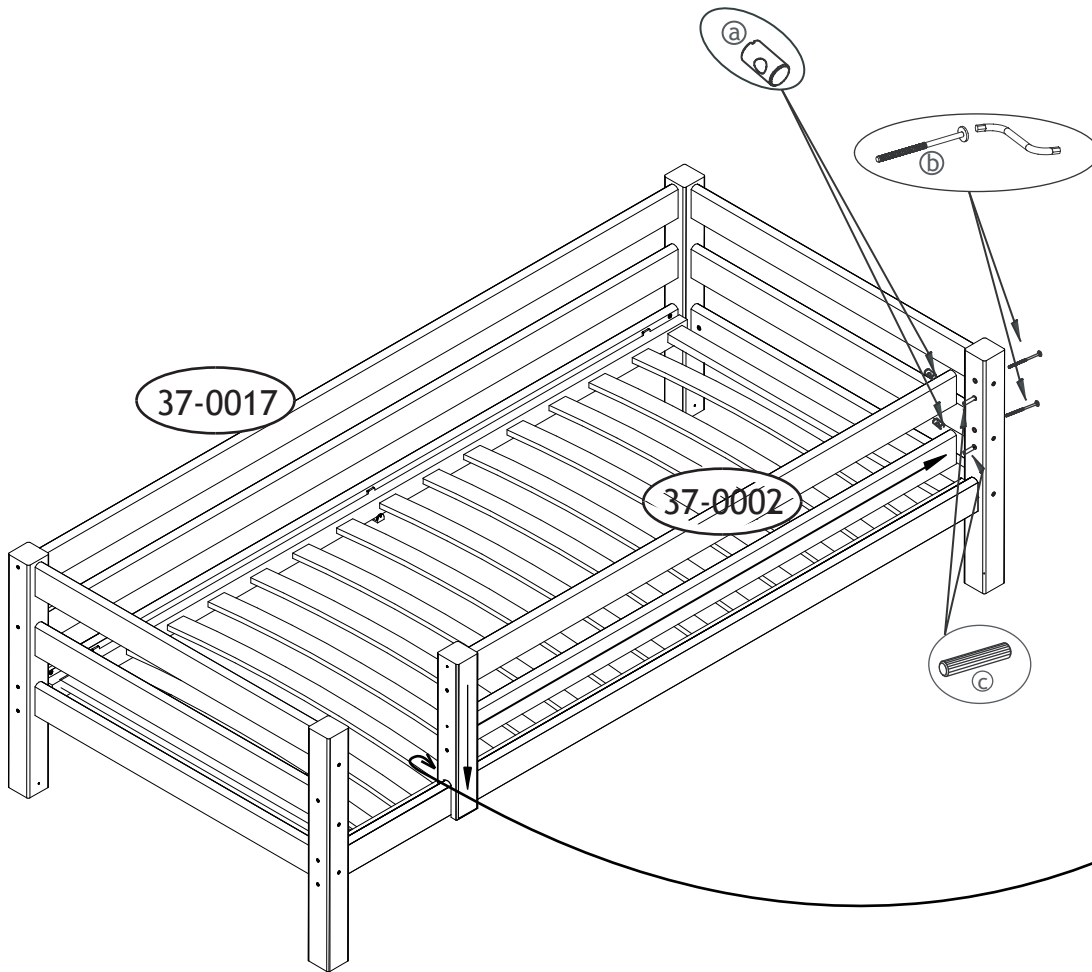

# 4.

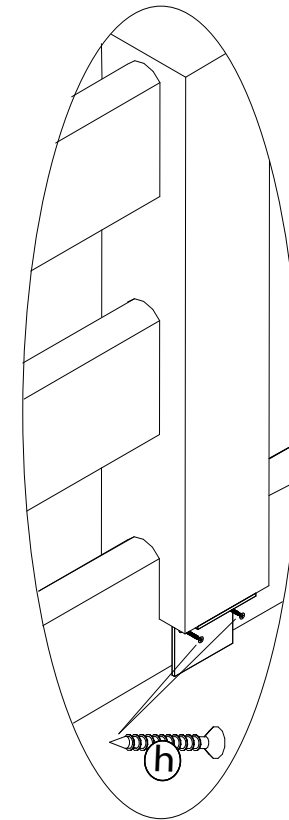

**UK** - Be aware of the risk of open fire and other heating sources close to the product

**DK** - Vær opmærksom på risikoen for åben ild og andre varmekilder i nærheden af produktet

**DE** - Berücksichtigen Sie die Gefahr des geöffneten Feuers und andere Wärmequellen nah an dem Produkt

**FR** - Ne pas placer le produit à proximité du feu ou du chauffage puissant

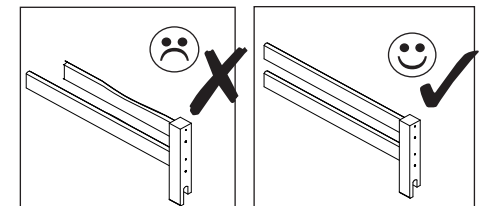

**Close free holes with caps**  
**Luk alle huller med propper**  
**Schliessen Sie die offenen Löcher mit den Deckkappen**  
**Fermez les trous découverts avec les chapes**



Ⓛ Aufbauanleitung

Ⓛ Notice de montage

Ⓛ Montagehandleiding

Ⓛ Montážní návod

Ⓛ Szerelési útmutató

Ⓛ Montaj talimatları

Ⓛ Assembly instruction

Ⓛ Istruzione di montaggio

Ⓛ Instrukcja montażu

Ⓛ Navod na montaž

Ⓛ Instrucțiuni de montaj

Ⓛ Инструкция по монтажу

# 37-0021-32-09A

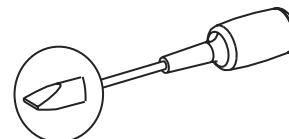
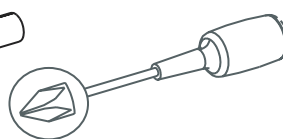
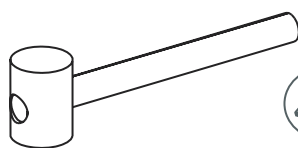
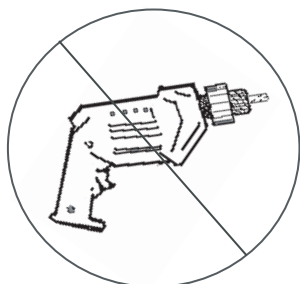
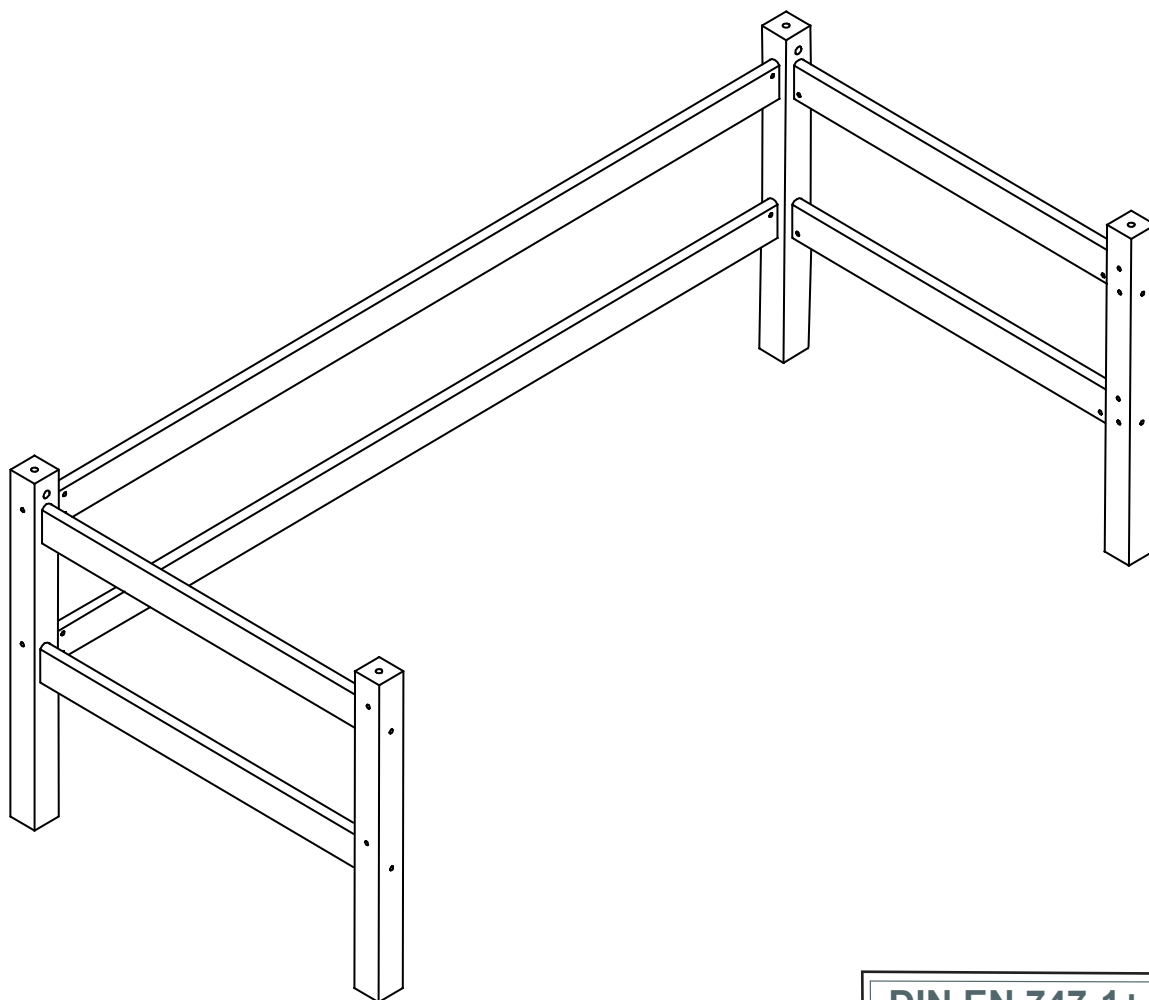

**DIN EN 747-1+A1:2015**  
**DIN EN 747-2+A1:2015**

Product fulfill the standard "DIN EN 747-1:2015,DIN EN 747-2:2015"  
Produktet opfylder krav til standard "DIN EN 747-1:2015,DIN EN 747-2:2015"  
Produkt entspricht der Norm "DIN EN 747-1:2015,DIN EN 747-2:2015"  
Produit conforme au standard "DIN EN 747-1:2015,DIN EN 747-2:2015"



**IMPORTANT-READ CAREFULLY AND RETAIN**  
**WICHTIG-SORGFÄLTIG LESEN UND AUFBEWAHREN**  
**VIGTIGT-LÆS grundigt igennem og opbevar**  
**IMPORTANT-LIRE ATTENTIVEMENT ET A CONSERVER**

# Service • Assistenza • Dienstverlening • Serwis Servis • Szerviz • Сервисная служба

Name • Nom • Nome • Naam • Nazwa • Jméno • Názov  
Név • Denumire • Isim • Название

Nr. Nr. • No. • N° • Č • Sz • Номер

Typ • Тип • Type • Tip • Tipus • Druh • Тиро • Тип

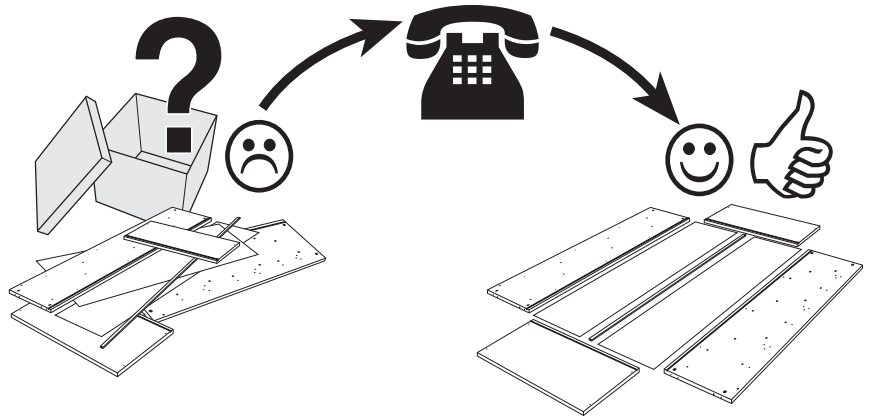
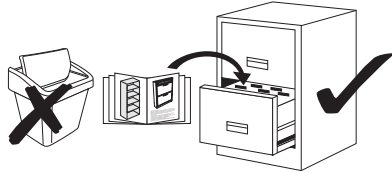

## Detail specification

A.i. Nr.	Article Nr.	pcs
4	013004-32	x2
6	013006-32	x4
56	013060-32	x2
57	013061-32	x2

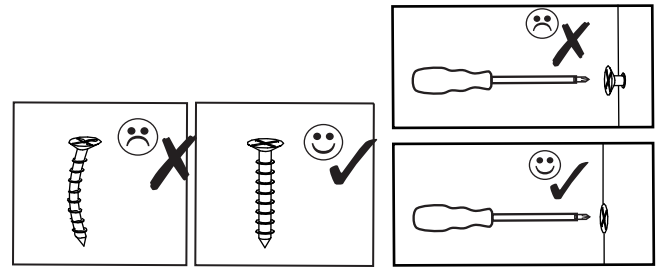
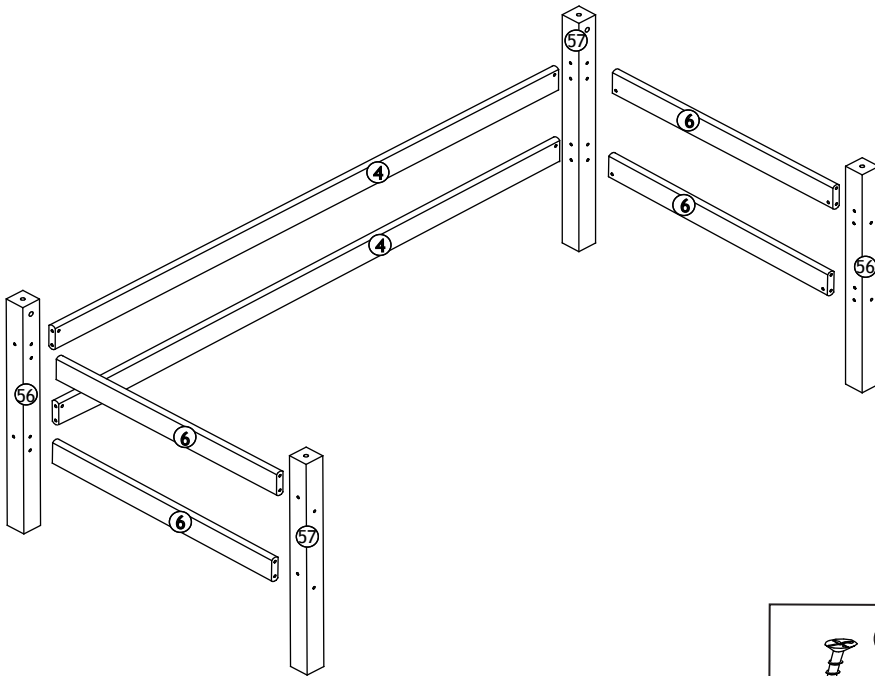

## Fitting specification

A.i. Nr.	Article Nr.	Dimentions	pcs
a	1-000011-07	M6x10/6	x12
b	1-000010-07	M6x100	x12
c	1-000013-00	8x40	x12
e	1-000014-57	6x8	x20
f	1-000015-07	Z4	x1
l	1-000021-07	M10x15/28	x4
m	1-000022-07	M10x15/28	x4
n	1-000023-07	M10x115	x4
k	1-000024-07	D16	x4
g	1-000016-57	16x10	x4

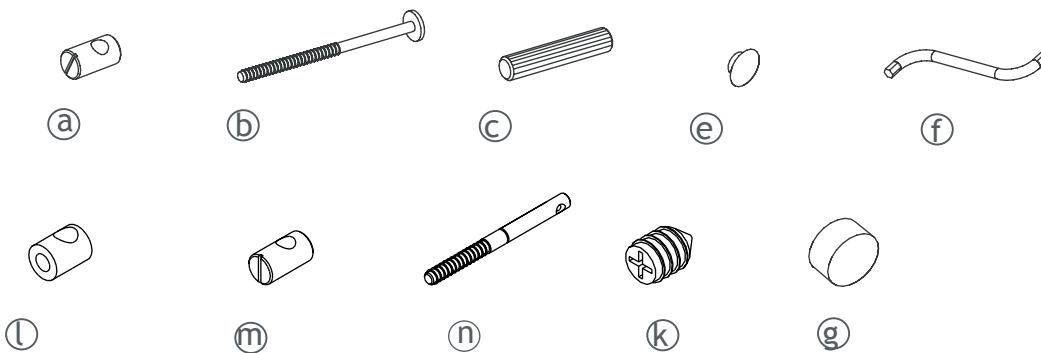

1-000001=

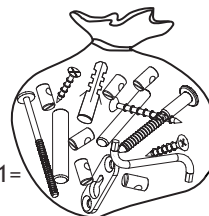

1.

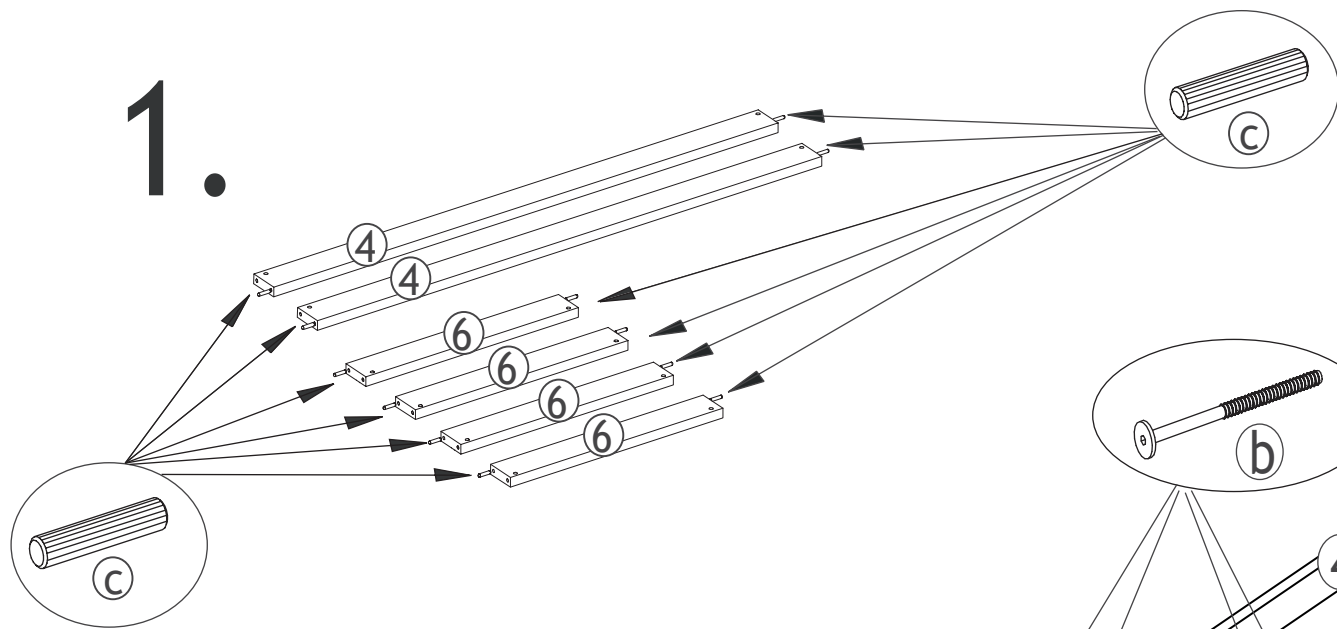

2.

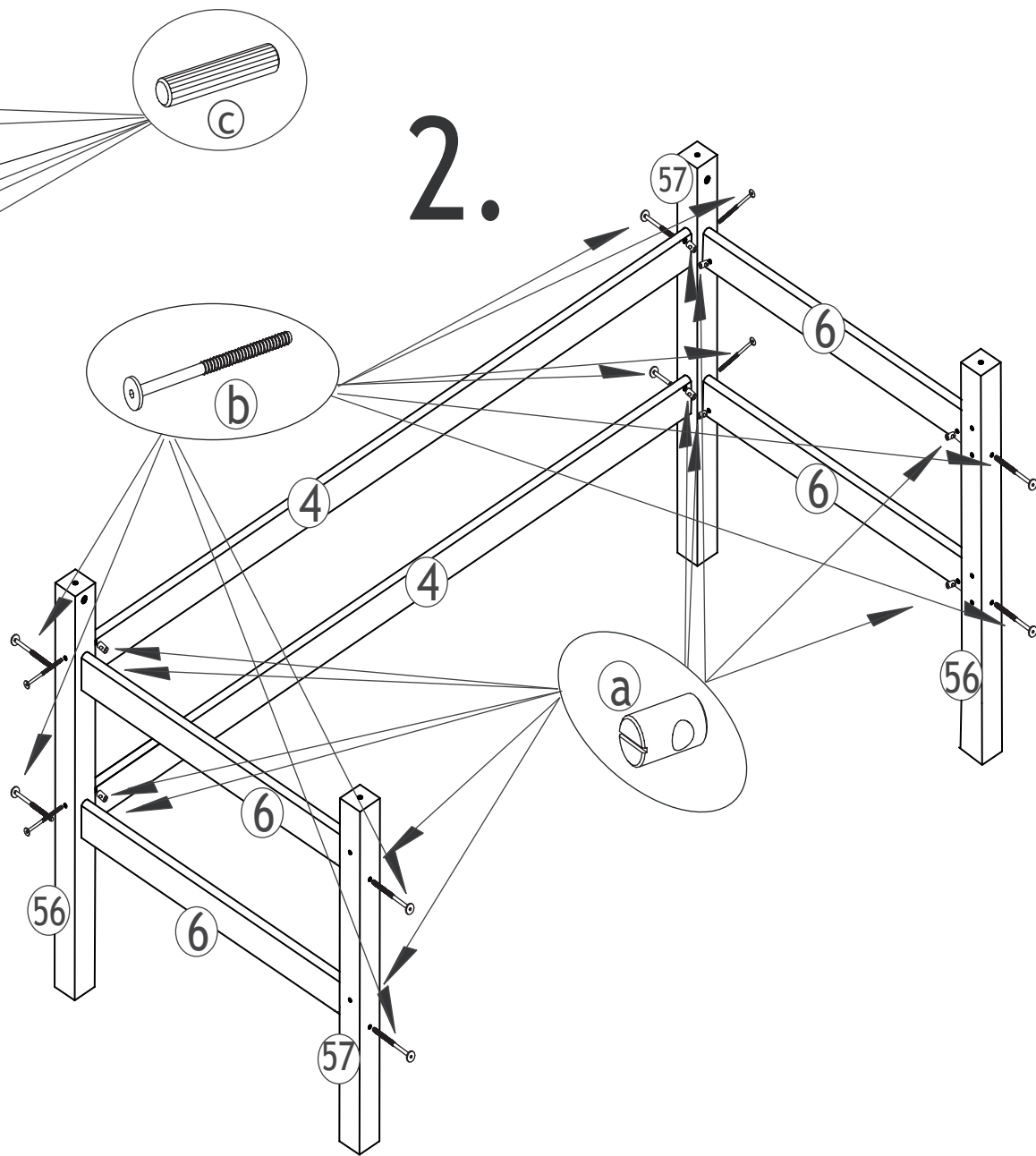

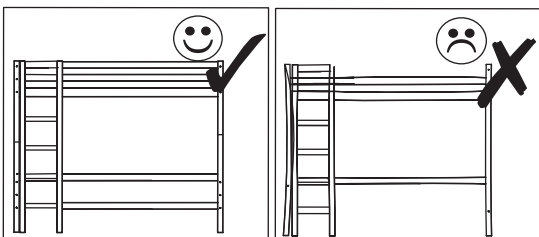
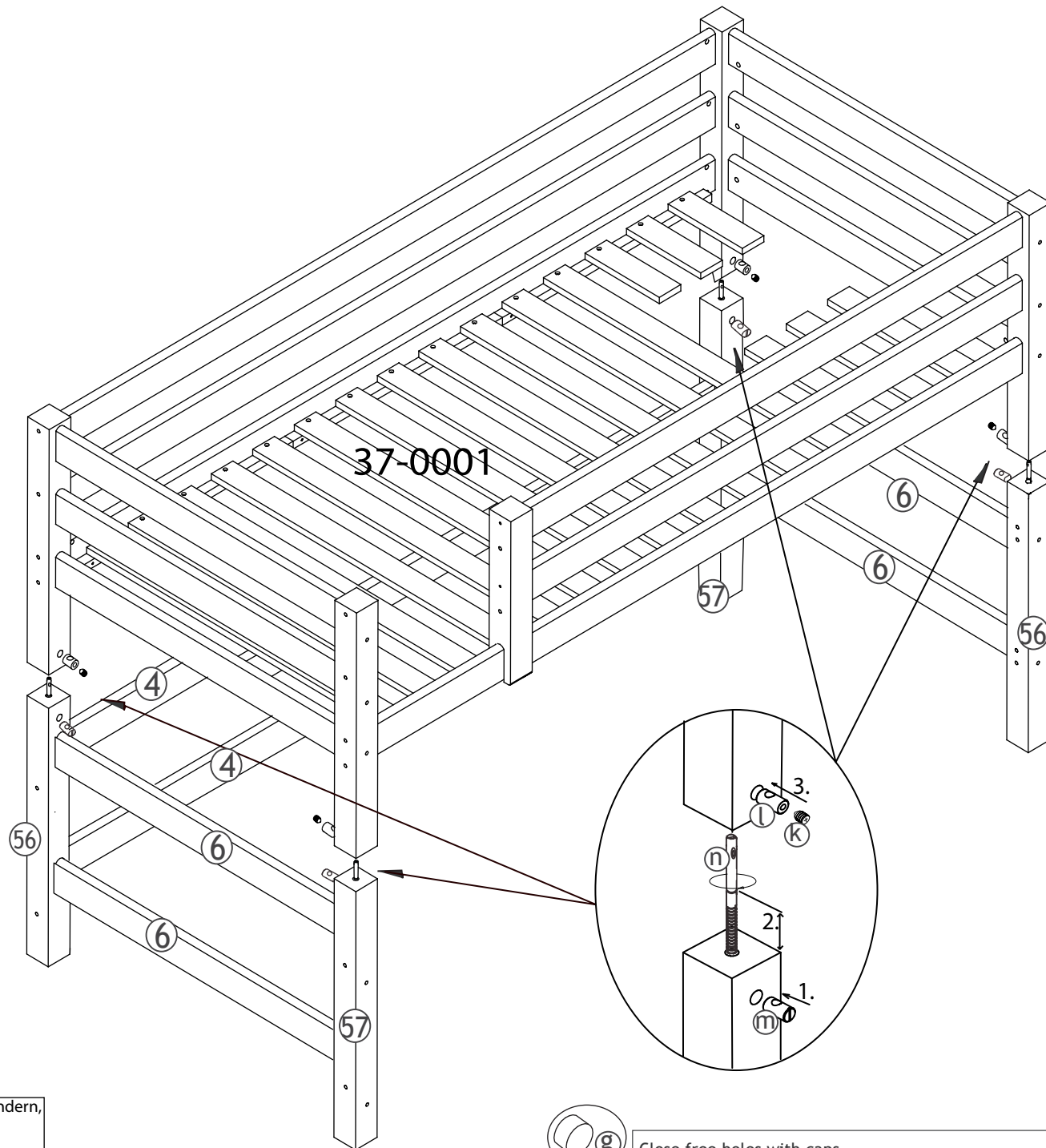

**DE** Halten Sie das Bett stets in Kontakt mit der Wand. Falls das nicht möglich ist, darf der Abstand zwischen der oberen Absturzsicherung und der Wand nicht mehr als 75 mm betragen oder der Abstand muß größer als 230 mm sein. Alle Schrauben und Befestigungen müssen immer fest sein. Stellen Sie sicher, dass es keine lose Schrauben gibt. DIN EN 747-1:2015

**UK** Please hold the bed straight in contact with the wall. If that is not possible, the distance between the upper safety rail and the wall may not be larger than 75 mm or it must be more than 230 mm. All Screws and fittings must always be tight. Ensure that there are not loose screws. DIN EN 747-1:2015

**FR** Tenez le lit droit contact avec le mur. Si ce n'est pas possible, la distance entre le rail supérieur de sûreté et le mur peut ne pas être plus grande que 75 millimètres ou elle doit être plus de 230 millimètres. Vérifier que la quincaillerie est bien vissée en permanence, faire attention à des vis qui peuvent se dévisser. DIN EN 747-1:2015

**DK** Hold venligt sengen i lige kontakt med væggen. Er dette ikke muligt må afstanden mellem øverste sengehest og væg ikke være mere end 75mm eller skal den være mere end 230mm. Alle skruer og beslag skal altid være strammet til. Vær opmærksom på, at der ikke er løse skruer. DIN EN 747-1:2015

**VORSICHT**-dass sich Kinder mit Gegenständen, z. B. Stricken, Schnüren, Kordeln, Gurten, Bändern, die an einem Etagenbett/Hochbett befestigt oder abhängt sind, strangulieren können

**Important** - that children with objects such as ropes, cords, cords, straps, bands, beginning at bunk bed / loft mounted or are dependent, strangulation

Hergestellt von: Hoppekids SIA / Novadnieki / LV-3801 / Saldus / www.hoppekids.com



Close free holes with caps  
Luk alle huller med propper  
Schliessen Sie die offenen Löcher mit den Deckkappen  
Fermez les trous découverts avec les chapes

Ⓛ Aufbauanleitung

Ⓛ Notice de montage

Ⓛ Handleiding voor de montage

Ⓛ Montážní návod

Ⓛ Szerelési útmutató

Ⓛ Montaj talimatları

Ⓛ Assembly instruction

Ⓛ Istruzione di montaggio

Ⓛ Instrukcja montażu

Ⓛ Navod na montaž

Ⓛ Instrucțiuni de montaj

Ⓛ Инструкция по монтажу

# 37-0023-32-000

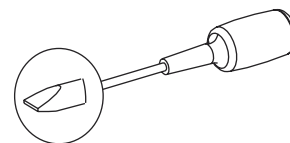
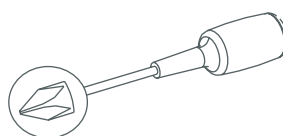
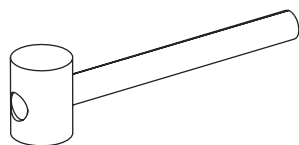
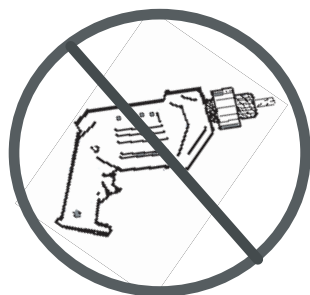
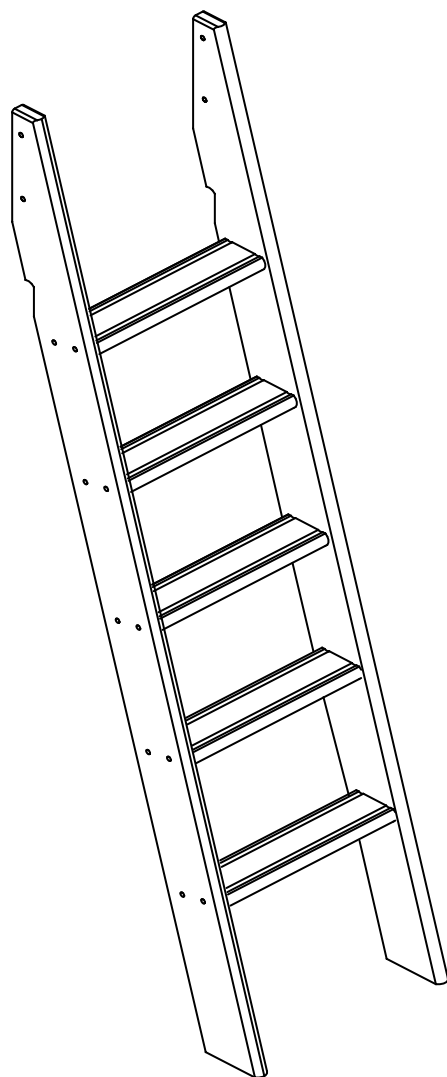

Product fullfil the standard "DIN EN 747-1:2015,DIN EN 747-2:2015"  
Produktet opfylder krav til standard "DIN EN 747-1:2015,DIN EN 747-2:2015"  
Produkt entspricht der Norm "DIN EN 747-1:2015,DIN EN 747-2:2015"  
Produit conforme au standard "DIN EN 747-1:2015,DIN EN 747-2:2015"

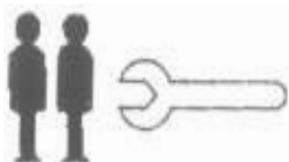

**DIN EN 747-1:2015**  
**DIN EN 747-2:2015**

**IMPORTANT-READ CAREFULLY AND RETAIN**  
**WICHTIG-SORGFÄLTIG LESEN UND AUFBEWAHREN**  
**VIGTIGT-LÆS grundigt igennem og opbevar**  
**IMPORTANT-LIRE ATTENTIVEMENT ET A CONSERVER**



# Service • Assistenza • Dienstverlening • Serwis Servis • Szerviz • Сервисная служба

Name • Nom • Nome • Naam • Nazwa • Jméno • Názov  
Név • Denumire • Isim • Название

Nr. • No. • N° • Č • Sz • Номер

Typ • Type • Tip • Tipus • Druh • Тіро • Тип

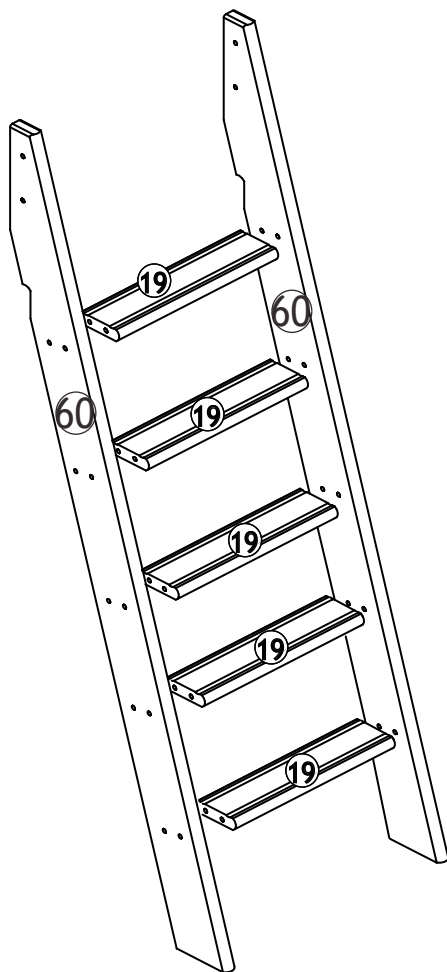
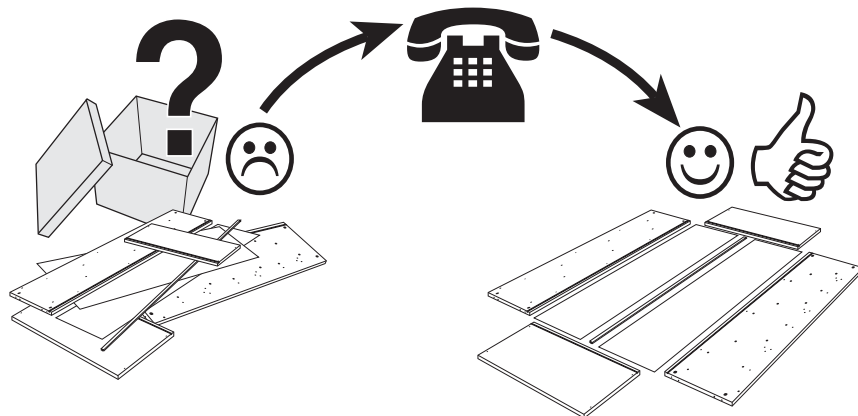
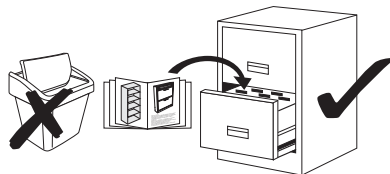

A.i. Nr.	Article Nr.	pcs
60	013118-32	x2
19	013018-32	x5

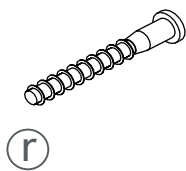
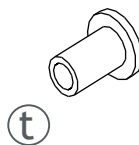
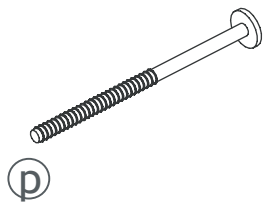
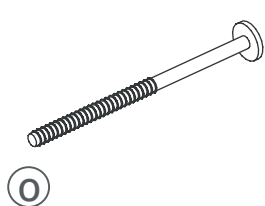
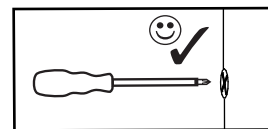
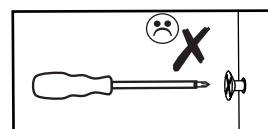
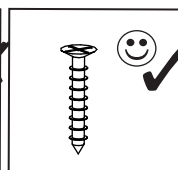
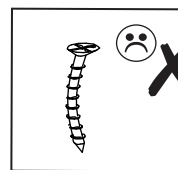

<b>O</b>	1-000025-07	M6x85	x2
<b>P</b>	1-000026-07	M6x120	x2
<b>T</b>	1-000027-07	8x15	x2
<b>E</b>	1-000014-57	8x13	x4
<b>R</b>	1-000028-07	7x60	x20
<b>S</b>	1-000029-07	4x50	x2

1-000001=

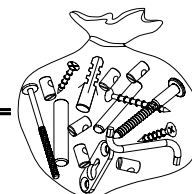



# 1.

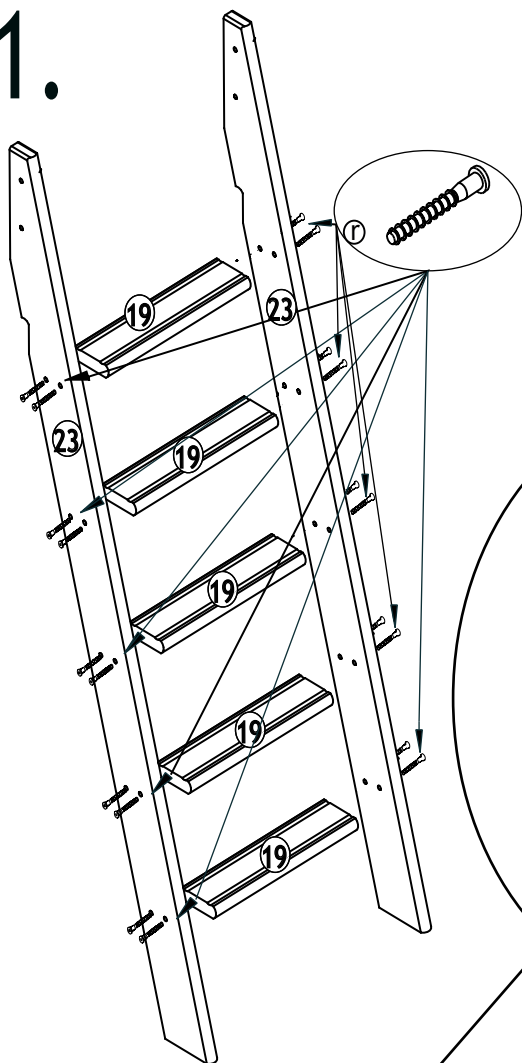

# 2.

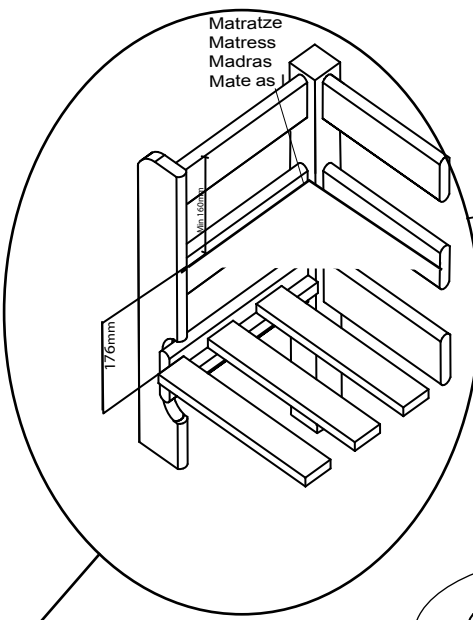
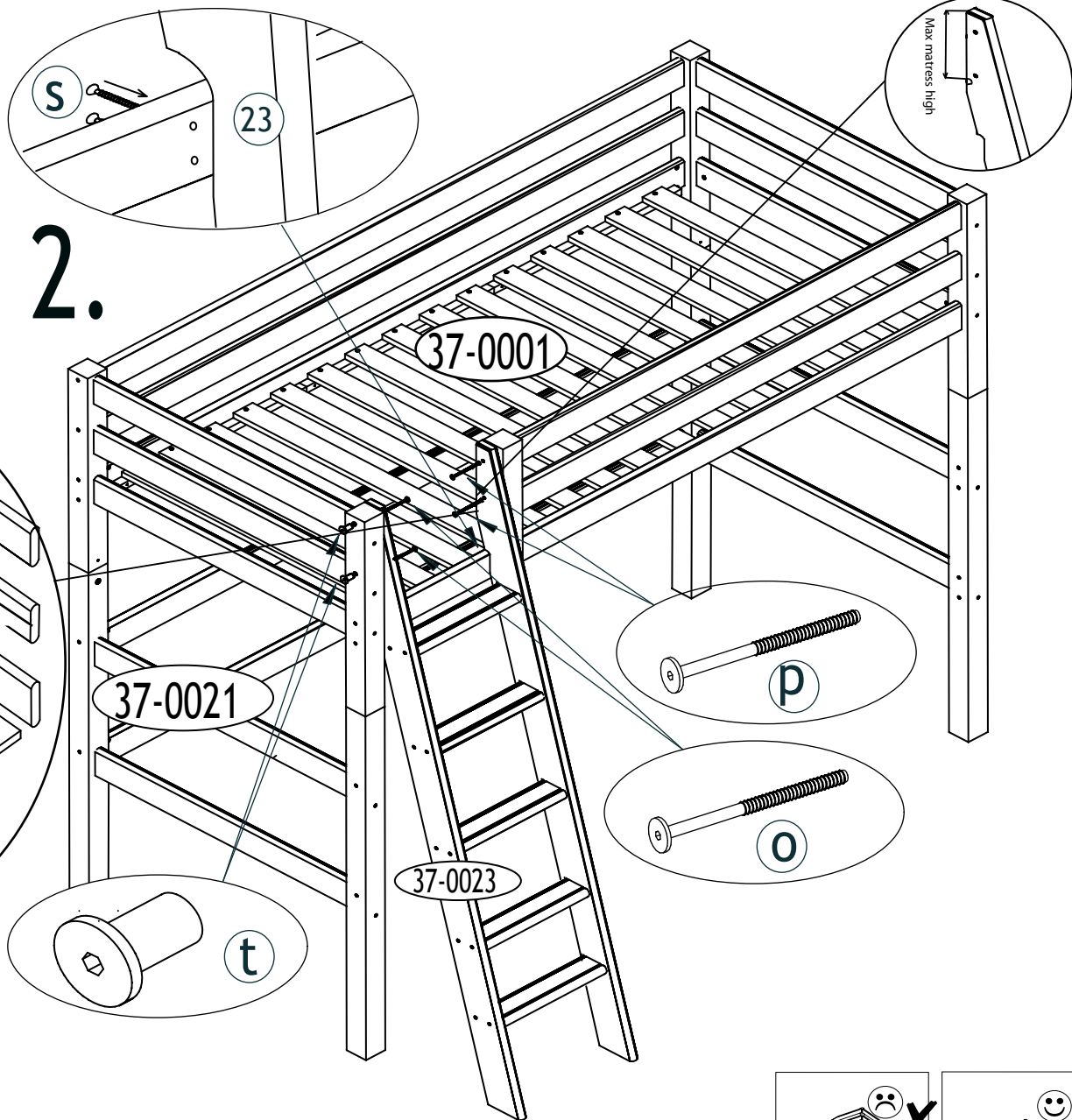

(P) Maksymalna wysokość materaca  
 (S) Značka maximálnej výšky matraca  
 (R) Semnul nivelului maxim de inaltime a saltelei  
 (D) Отметка для максимальной высоты матраса  
 DIN EN 747-1:2012

(H) A maximális matracmagasság jelölése  
 (T) Yatak minderinin gelebileceği en yüksek yer işareti  
 (B) Mark of maximal mattress height level  
 (I) Segno di massima altezza di livello del materasso

(D) Markierung für die maximale Matratzenhöhe  
 (R) Marque de la hauteur maximum du matelas  
 (D) Markering van het maximale matrashoogte niveau  
 (Z) Značka maximální výšky matrace

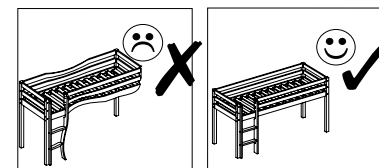

Close free holes with caps  
 Luk alle huller med propper  
 Schliessen Sie die offenen Löcher mit den Deckkappen  
 Fermez les trous découverts avec les chapes



- Ⓓ Das Bett muss in der Nähe der Wand stehen, d. h. einseitig muss die Wand berühren, wenn es nicht möglich, der Abstand zwischen dem Bett und der Wand nicht größer als 75mm sein darf es größer als 230mm sein muss, so dass das Kind, sollte es herausfallen, könnte nicht zwischen Bett und Wand erwischt. Sollte nicht verwendet werden, wenn struktureller Teil defekt oder fehlt. Alle und Verbindung muss immer stabil sein. Stellen Sie sicher, dass es keine losen gibt und verlassen Sie Schrauben zu!  
DIN EN 747-1:2015
- Ⓔ Le lit doit se tenir près de la paroi, c'est à dire d'un côté doit toucher le mur, si ce n'est pas possible, la distance entre le lit et le mur ne doit pas être supérieure à 75 mm ou elle doit être à 230 mm, de sorte que l'enfant, devraient il tomber, ne pouvait pas se faire prendre entre le lit et le wall. pas être utilisé si une partie structurelle est cassé ou missing. Evry srew et connexion doit toujours constante. Assurez-vous qu'il n'y a pas lâches et laissent vis!  
DIN EN 747-1:2015
- Ⓗ Het bed moet in de buurt van de muur te staan, dat wil zeggen de ene kant moet de muur raken, indien het niet mogelijk is, moet de afstand tussen het bed en de muur niet groter dan 75mm zijn of het moet groter zijn dan 230mm zijn, zodat het kind moet het vallen, niet kon raken tussen het bed en de wall. Should niet gebruikt worden als er structureel onderdeel is of missing. Evry srew en verbinding moet altijd stabiel zijn. Zorg ervoor dat er geen losse en laat schroeven!  
DIN EN 747-1:2015
- Ⓒ Postel musí stát u zdi, tedy jedna strana musí dotknout stěny, pokud je to možné, vzdálenost mezi postelí a zdi nesmí být větší než 75 mm, nebo musí být větší než 230 mm, aby dítě, mělo by vypadnout, nemohl být vtaženy mezi postelí a stěnou. Nepoužívejte je-li konstrukční část je poškozená nebo chybí. Každý šroub a připojení musí být vždy stabilní. Ujistěte se, že neexistují ne volné a nechte šrouby!  
DIN EN 747-1:2015
- Ⓗ Az ágy meg kell állni, a fal mellett, azaz egyik oldalon kell érint a fal, ha lehetséges, az ágy és a fal közötti távolság nem lehet nagyobb, mint 75 mm és 230 mm-nél nagyobb kell, hogy a gyermek, kell, hogy kiesik, nem kap megfogott az ágy és a fal között. Nem használható ha olyan szerkezeti rész hibás vagy hiányzó. Minden csavar és a kapcsolat mindig kell állandó. Győződjön arról, hogy nem laza, és hagyjuk a csavarokat!  
DIN EN 747-1:2015
- Ⓓ Yatağı duvara yakın durmak gerekir, mümkünür, yatak ve duvar arasındaki mesafeyi 75 mm daha büyük olmamalıdır veya böylece o çocuk, gereken 230 mm büyük olmalıdır, yani bir yana duvar, dokunmatik gerekir dağılın, yatak ve duvar arasında değil. Yapısal bir parçası eksik veya kırık ise kullanılmamalıdır. Her vida ile bağlantısı her zaman sabit olmalıdır. Hayır serbest olduğundan emin olun ve vidalar bırakın!  
DIN EN 747-1:2015
- Ⓖ The bed must stand near the wall, i.e. one side must touch the wall, if it is not possible, the distance between the bed and the wall must not be greater than 75mm or it must be greater than 230mm, so that the child, should it fall out, could not get caught between the bed and the wall. Should not be used if any structural part is broken or missing. Every screw and connection must always be steady. Make sure that there are no loose and leave screws!  
DIN EN 747-1:2015
- Ⓗ Il letto deve stare vicino al muro, cioè un lato deve toccare il muro, se è possibile, la distanza tra il letto e la parete non deve essere maggiore di 75 mm o deve essere superiore a 230 mm, così che il bambino, dovrebbe cadere, non poteva rimanere intrappolati tra il letto e il muro. Non deve essere utilizzato se qualsiasi parte strutturale è rotto o mancante. Ogni vite e connessione deve essere sempre costante. Assicurarsi che non ci sono non sciolto e lasciare le viti!  
DIN EN 747-1:2015
- Ⓓ Łóżko musi stanać przy ścianie, czyli z jednej strony musi dotknąć ściany, jeśli jest to możliwe, odległość między łóżkiem a ścianą nie może być większa niż 75 mm lub musi być większa niż 230 mm, tak, że dziecko, powinien wypaść, nie mógł złapać między łóżkiem a ścianą. Nie powinny być stosowane. Jeśli jakakolwiek część strukturalnych jest uszkodzony lub brakuje. śruba i połączenie musi być zawsze stały. Upewnij się, że istnieją nie luźne i pozostawić śruby!  
DIN EN 747-1:2015
- Ⓔ Postel' musí stát' v blízkosti steny, t. j. na jednej strane sa musí dotýkať steny, či je možné, vzdialenosť medzi posteľou a steny nesmie byť väčšia než 75 mm musí byť väčšia než 230 mm, tak, že dieťa by malo vypadnúť, nie sa chytiť medzi posteľou a steny. Sa nepoužívajú ak konštrukčná časť je poškodený alebo chýba. Každý skrutku a pripojenie musí byť vždy stabilné. Uistite sa, že neexistujú žiadne voľné a nechať skrutky!  
DIN EN 747-1:2015
- Ⓓ Pat trebuie să stea lângă perete, adică de o parte trebuie să atingeți perete, dacă este posibil, distanța dintre pat și peretele nu trebuie să fie mai mare de 75 mm sau trebuie să fie mai mare de 230 mm, astfel încât copilul, ar trebui să cadă, nu ar putea fi prins între pat și peretele. Nu trebuie utilizat în cazul în care orice parte structurală este rupt sau lipsește. Fiecare șurub și conexiune trebuie să fie întotdeauna constantă. Asigurați-vă că nu există nu vrac și se lasă șuruburi!  
DIN EN 747-1:2015
- Ⓓ Кровать должна стоять у стены, т.е. одна сторона должна касаться стены, если это возможно, расстояние между кроватью и стеной должно быть не больше 75 мм или оно должно быть больше чем 230 мм, таким образом, чтобы , если он выпадет, не может попасть между кроватью и стеной. Не быть используется, если какой-либо структурной части сломаны или отсутствуют. Каждый винт и связи должны быть всегда стабильный. Убедитесь, что есть нет свободных и оставить винты!  
DIN EN 747-1:2015

Ⓓ Aufbauanleitung

Ⓕ Notice de montage

Ⓖ Montagehandleiding

Ⓒ Montážní návod

Ⓗ Szerelési útmutató

Ⓙ Montaj talimatları

Ⓖ Assembly instruction

Ⓙ Istruzioni di montaggio

Ⓙ Instrukcja montażu

Ⓙ Navod na montaž

Ⓙ Instrucțiuni de montaj

Ⓙ Инструкция по монтажу

# 37-0031-82-000

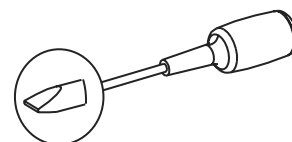
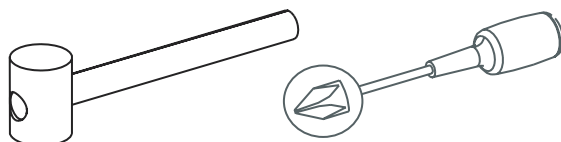
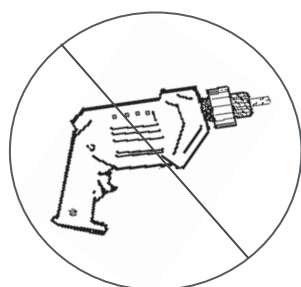
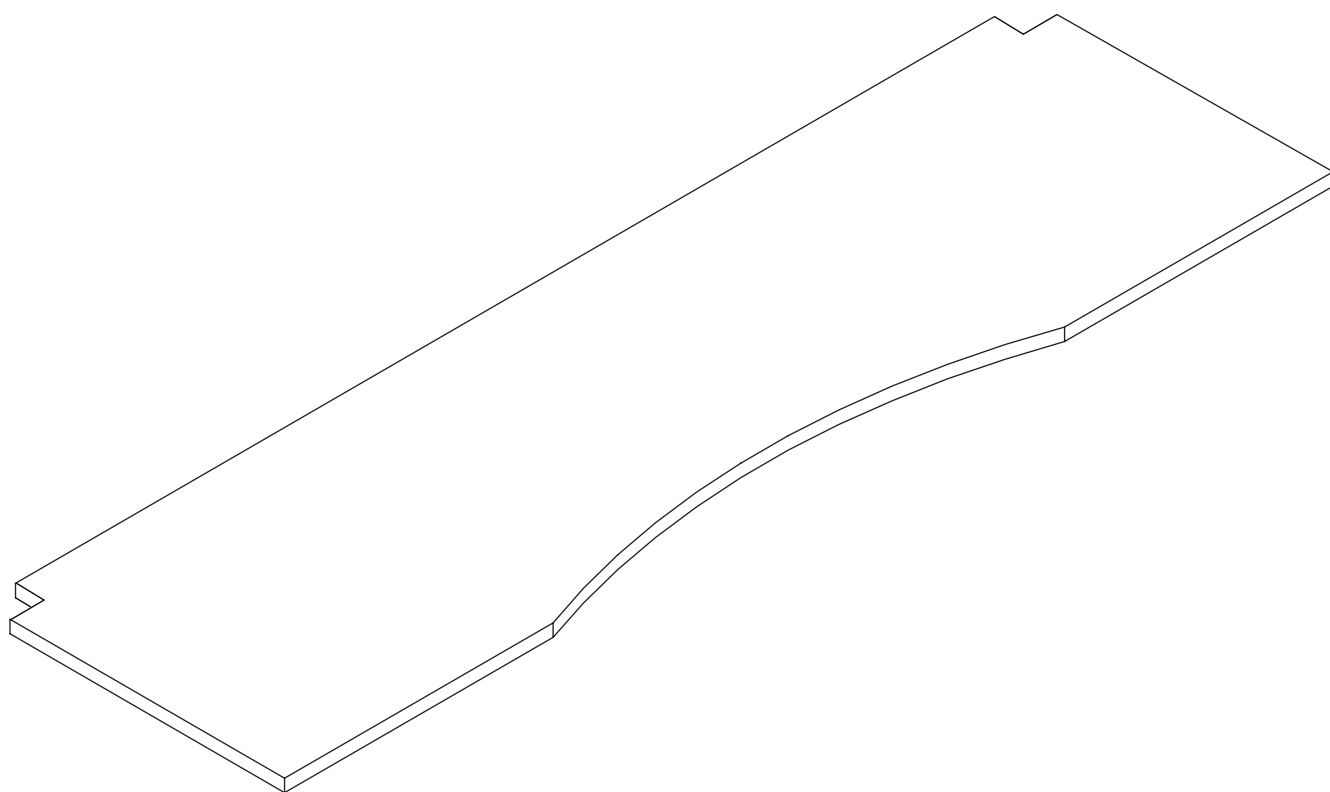

# Service • Assistenza • Dienstverlening • Serwis Servis • Szerviz • Сервисная служба

Name • Nom • Nome • Naam • Nazwa • Jméno • Názov  
Név • Denumire • Isim • Название

Nr. Nr. • No. • N° • Č • Sz • Номер

Typ • Тип • Type • Tip • Tipus • Druh • Тиро • Тип

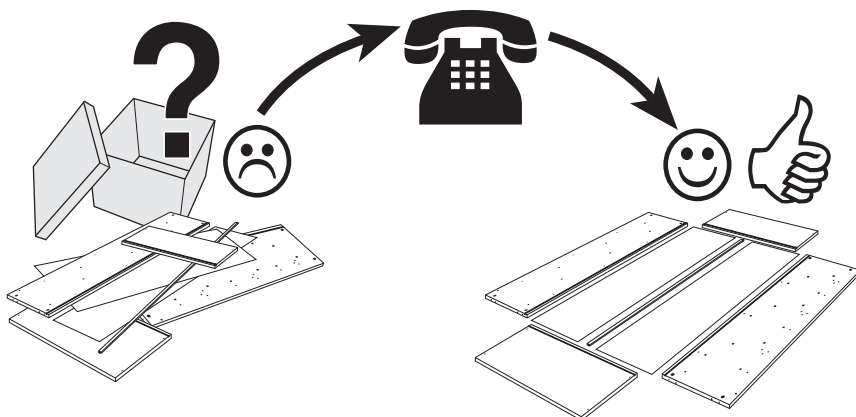
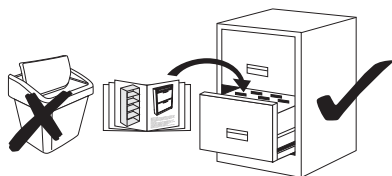

## Detail specification

A.i. Nr.	Article Nr.	pcs
①	208451-82	x1
②	208452-32	x2

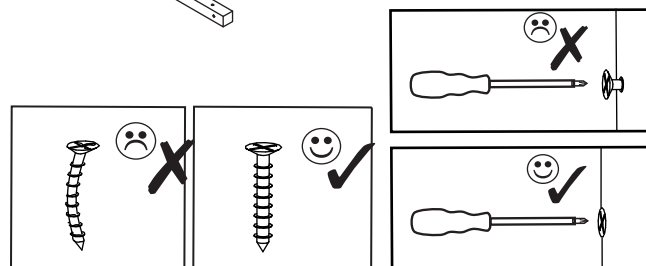
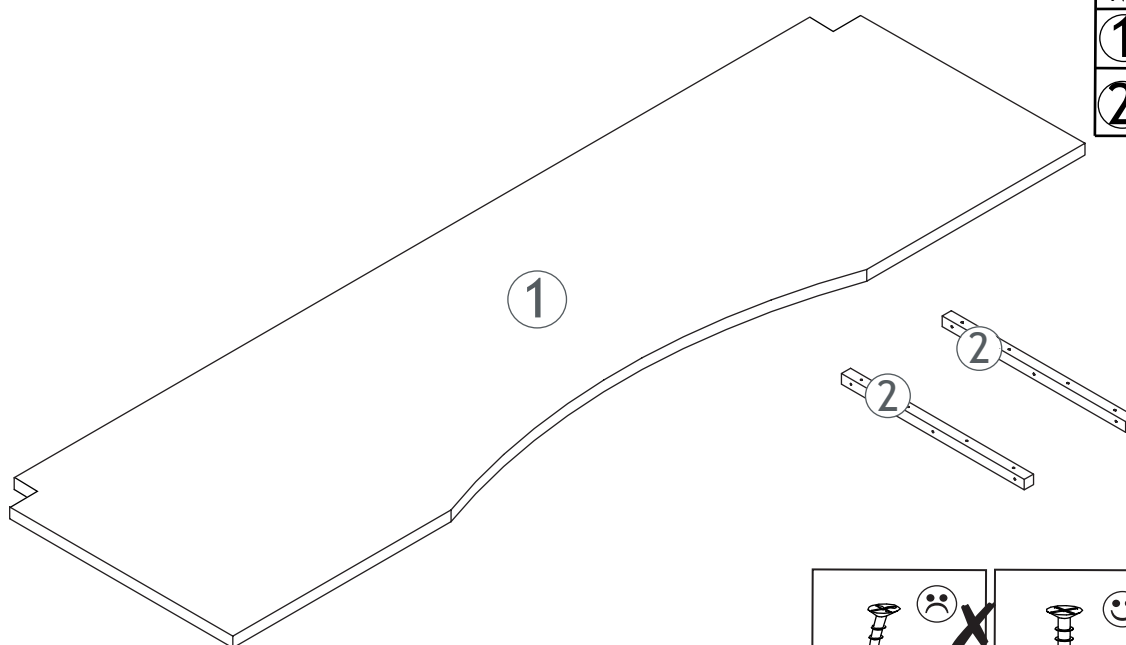

## Fitting specification

A.i. Nr.	Article Nr.	Dimintions	pcs
Ⓐ	1-000094-07	3,5X40	x14

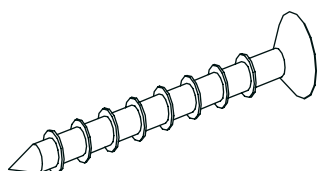

a

Make sure that there are no loose and leave screws!  
Stellen Sie sicher, dass keine losen Schrauben und verlassen!  
Zorg ervoor dat er geen losse en laat schroeven!  
Assurez-vous qu'il n'y a pas lâches et laissent vis!

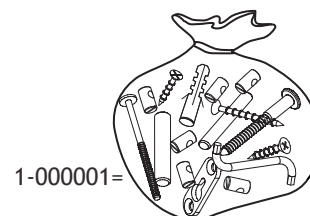

1-000001=

1.

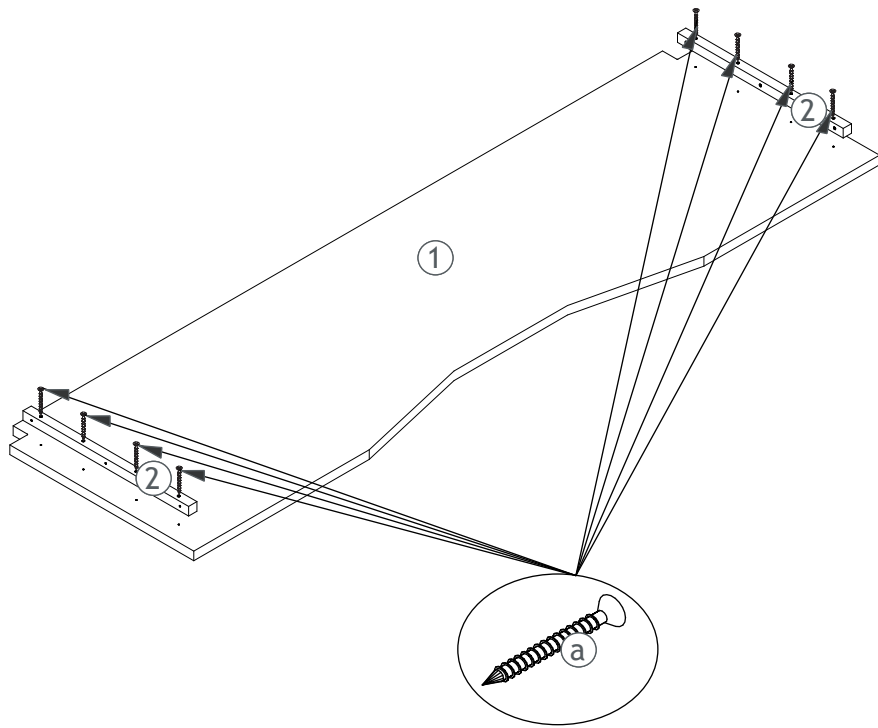

2.

